

ISAL s.r.l. con Unico Socio  
Società soggetta all'attività di direzione e  
coordinamento di Kaercher Beteiligungs GmbH

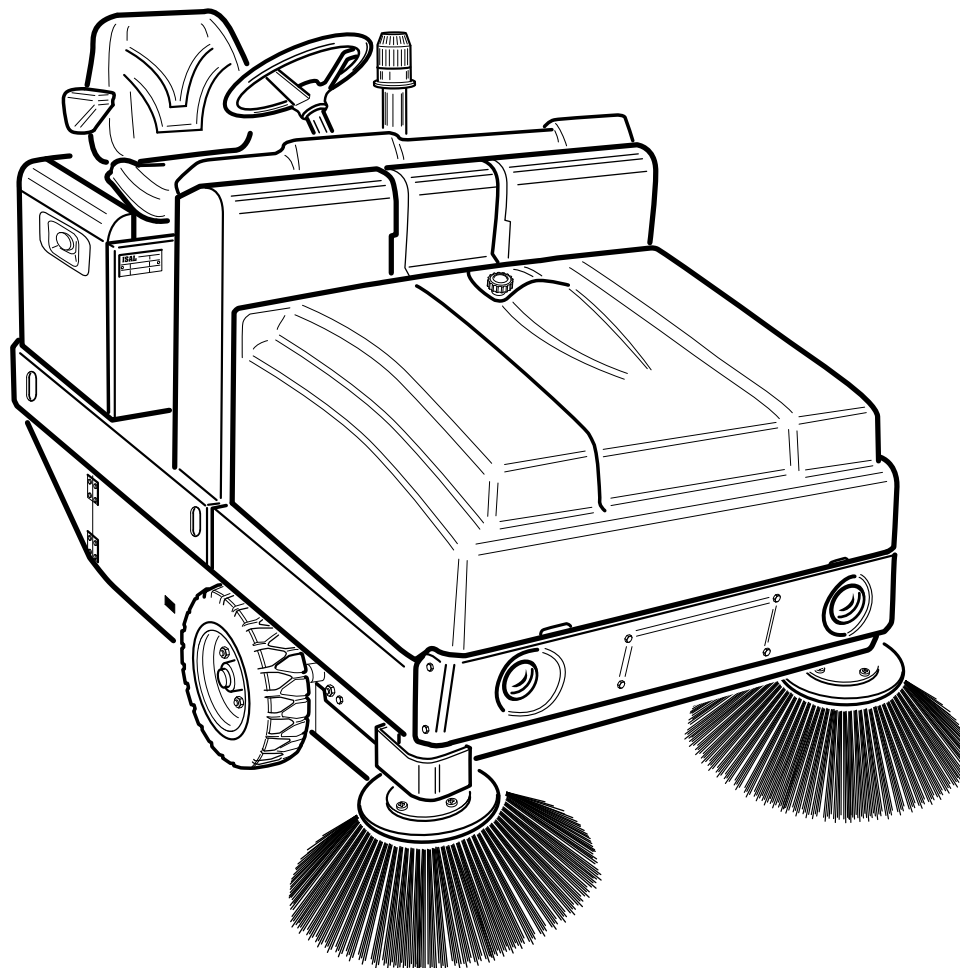

CE



**ATTENZIONE:** Prima di utilizzare la macchina leggere attentamente questo libretto di istruzioni.

**WARNING:** Read the instructions before using the machine.

**ATTENTION:** Avant d'utiliser la machine, lire attentivement ce manuel d'instructions.

**ACHTUNG:** Vor dem Gebrauch der Maschine, lesen Sie diese Betriebsanleitung sorgfältig durch.

**ATENCIÓN:** Antes que utilize la máquina lea atentamente este manual de instrucciones.



**IT**

## MANUALE D'USO E MANUTENZIONE

Istruzioni originali

**EN**

## INSTRUCTION AND MAINTENANCE MANUAL

Translation of original instructions

**FR**

## MANUEL D'INSTRUCTIONS ET D'ENTRETIEN

Traduction du mode d'emploi original

**DE**

## BETRIEBS-UND WARTUNGSANLEITUNG

Übersetzung der Original-Bedienungsanleitung

**ES**

## MANUAL DE INSTRUCCIONES Y MANTENIMIENTO

Traducción de las instrucciones originales



**DICHIARAZIONE DI CONFORMITÀ - DECLARATION OF CONFORMITY  
DECLARATION DE CONFORMITÉ - KONFORMITÄTSERKLÄRUNG  
DECLARACION DE CONFORMIDAD**

**Applicazione della direttiva 2006/95/CE e delle norme di prodotto:**

Application of the directive 2006/95/CE and product regulations:  
Application de la directive 2006/95/CE et des Normes de Produit:  
Anwendung der Richtlinie 2006/95/CE und den Produktnormen:  
Aplicacion de la directiva 2006/95/CE y de las normas de producto:

**EN 60335-1  
60335-2-72**

**Nome del fabbricante**

Name of manufacturer  
Nom du fabricant  
Herstellersname  
Nombre del constructor

**ISAL s.r.l. con Unico Socio**

Società soggetta all'attività di direzione e coordinamento  
di Kaercher Beteiligungs GmbH

**Indirizzo del fabbricante**

Address of manufacturer  
Adresse du fabricant  
Herstellersadresse  
Direccion del constructor

**Via P. Colletta, 19  
42124 REGGIO EMILIA - ITALY**

**Descrizione del materiale**

Description of goods  
Description des marchandises  
Waerenbeschreibung  
Descripcion del producto

**Motospazzatrice - Motorsweeper  
Balayeuse - Kehrmaschine - Barredora**

**Modello / Tipo / Denominazione Commerciale**

Model / Type / Commercial name  
Modèle / Genre / Appellation commercial  
Modell / Typ / Geschaeftsname  
Modelo / Tipo / Denominación comercial

**160 DK**

**N. di serie**

Serial number  
Numéro de série  
Seriennummer  
Número de serie

**0110121**

**Anno di fabbricazione**

Year of Manufacturing  
Année de fabrication  
Herstellungsjahr  
Año de fabricacion

**Il sottoscritto dichiara che il materiale di cui sopra è interamente conforme alle direttive:**

The undersigned hereby declares that the above mentioned goods entirely conform to the EEC directives:  
Le soussigné déclare que le matériel cité au dessus est entièrement conforme aux directives:  
Der Unterzeichnete erklärt, daß die o.g. Waren vollständig den EG Vorschriften entsprechen:  
El abajo firmado declara que el producto citado arriba es conforme a las directivas:

**2000/14/CE  
2006/42/CE  
2014/30/CE**

**Persona autorizzata a costituire il Fascicolo Tecnico**

Person authorized to constitute the Technical File  
Personne autorisée à constituer le Dossier Technique  
Autorisierte Person um die Fach-Feile zu bilden  
Persona autorizada para eleborar el Expediente Técnico

**ISAL s.r.l. con Unico Socio  
Via P.Colletta, 19  
42124 REGGIO EMILIA - Italy**



**ISAL s.r.l. con Unico Socio**  
Società soggetta all'attività di  
direzione e coordinamento di Kaercher  
Beteiligungs GmbH

**REGGIO EMILIA  
ITALY**



**Giuseppe Del Duca**  
Amministratore Delegato

**Data - Date - Date - Datum - Fecha**

	Pag.
<b>CERTIFICAZIONE CE - CE CERTIFICATION</b>	
<b>CE CERTIFICATION</b> CE-KONFORMITÄTSBESCHEINIGUNG- CERTIFICACION .....	2
<b>INDICE - INDEX</b>	
<b>SOMMAIRE - INHALT - INDICE</b> .....	3
<b>1. INTRODUZIONE - INTRODUCTION</b>	
INTRODUCTION - VORBEMERKUNG - INTRODUCCION .....	4
<b>2. PREPARAZIONE - PREPARATION</b>	
PREPARATION - VORBEREITUNG - PREPARACION .....	4
<b>3. CONDIZIONI AMBIENTALI CONSENTITE - PERMITTED ENVIROMENTAL CONDITIONS</b>	
CONDITIONS ENVIRONNEMENT PERMISES - ZULÄSSIGE UMGEBUNGSTEMPERATUREN - CONDICIONES AMB. PERMITIDAS .....	4
<b>4. CONDIZIONI DI UTILIZZO - CONDITIONS OF USE</b>	
CONDITIONS D' UTILISATION - EINSATZBEDINGUNGEN - CONDICIONES DE UTILIZACION .....	6
<b>5. CARATTERISTICHE TECNICHE - TECHNICAL DATA</b>	
CARACTERISTIQUES TECHNIQUES - TECHNISCHE DATEN - CARACTERISTICAS TECNICAS .....	8
<b>6. DESCRIZIONE DELLA MACCHINA - DESCRIPTION OF THE MACHINE</b>	
DESCRIPTION DE LA MACHINE - MASCHINENBESCHREIBUNG - DESCRIPCION DE LA MÁQUINA .....	14
<b>7. POSTO DI LAVORO OCCUPATO DALL'OPERATORE/ARRESTO DI EMERGENZA - OPERATOR / EMERGENCY STOP PLACE DE TRAVAIL .</b>	
OCCUPEE PAR L'OPERATEUR / ARRET D'URGENCE - ARBEITSPOSITION DES BEDIENERS / NOT- AUSSCHALTUNG - PUESTO DE .....	
TRABAJO OCUPADO POR EL OPERADOR / PARADA DE EMERGENCIA .....	20
<b>8. NORME DI SICUREZZA - SAFETY RULES AND REGULATIONS</b>	
NORMES DE SECURITE - SICHERHEITSVORSCHRIFTEN - NORMAS DE SEGURIDAD .....	22
<b>9. CONTROLLI PRIMA DELL'AVVIAMENTO - CHECKS PRIOR TO STARTING UP</b>	
CONTROLES AVANT MISE EN MARCHÉ - KONTROLLEN VOR DER INBETRIEBNAHME - CONTROLES ANTES PUESTA EN MARCHA' .....	24
<b>10. USO CORRETTO E CONSIGLI - CORRECT USE - SOME ADVICE</b>	
EMPLOI CORRECT ET CONSEILS- RICHTIGER GEBRAUCH UND EMPFEHLUNGEN - USO CORRECTO Y CONSEJOS .....	26
<b>11. INTERVENTI DI MANUTENZIONE ORDINARIA - ROUTINE MAINTENANCE</b>	
INTERVENTIONS D'ENTRETIEN ORDINAIRE - WARTUNGSPROGRAMM - INTERVENCIONES DE MANUTENCION ORDINARIA .....	26
<b>12. MANUTENZIONI STRAORDINARIE - EXTRAORDINARY MAINTENANCE</b>	
ENTRETIENS EXTRAORDINAIRES - AUSSERORDENTLICHE WARTUNGSMASSNAHMEN - MANUTENCIONES EXTRAORDINARIAS .....	32
<b>13. MESSA FUORI SERVIZIO - LEAVING THE SWEEPER UNUSED FOR LONG PERIODS OF TIME</b>	
MISE HORS SERVICE - AUSSERBETRIEBSETZUNG - PUESTA FUERA SERVICIO .....	32
<b>14. SMANTELLAMENTO / DEMOLIZIONE - DISMANTLING / DEMOLITION</b>	
DEMANTELEMENT / DEMOLITION - ENTSORGUNG / VERSCHROTTUNG - DESMANTELAMIENTO / DEMOLICION .....	34
<b>15. SITUAZIONI DI EMERGENZA - EMERGENCY SITUATIONS</b>	
SITUATIONS D'URGENCE - NOTSITUATIONEN - SITUACIONES DE EMERGENCIA .....	34
<b>16. DIFETTI - CAUSE - RIMEDI - TROUBLESHOOTING</b>	
DEFAULTS- CAUSES - REMEDES - STÖRUNGEN - URSACHEN - BEHEBUNG - DEFECTOS- CAUSAS - REMEDIOS .....	34
<b>17. ESPLOSO CON ELENCO RICAMBI - EXPLODED VIEW AND SPARE PARTS LIST</b>	
VUE ECLATEE AVEC LISTE RECHANGES- EXPLOSIONSDARSTELLUNG MIT ERSATZTEILLISTE - EXPLOSO CON LISTA REPUESTOS. ....	39

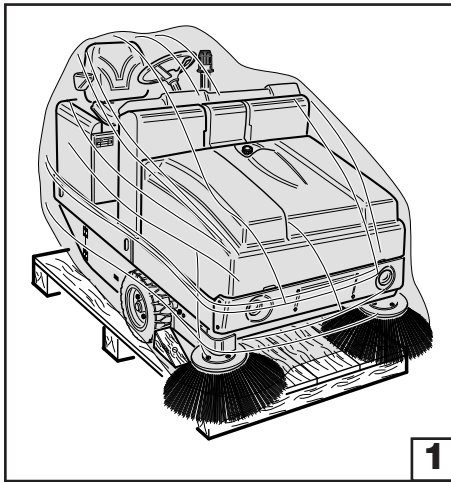

## 1. INTRODUZIONE

**ATTENZIONE:** Prima di utilizzare la macchina leggere attentamente questo libretto di istruzioni.



N.B: Tutti gli strumenti che si renderanno necessari per la protezione personale dell'utilizzatore ad esempio guanti, mascherine per evitare di inalare polveri nocive, occhiali a lenti bianche, chiavi ed utensili per eseguire registrazioni o sostituzioni in genere sono di fornitura dell'utilizzatore.

## 1. INTRODUCTION

**ATTENTION:** Read this instruction handbook through carefully before using the sweeper.



N.B: Everything necessary for personal protection of the user such as gloves, masks to prevent the inhalation of harmful dust, goggles with clear lenses, wrenches and tools for adjusting or replacing parts, are normally provided by the user.

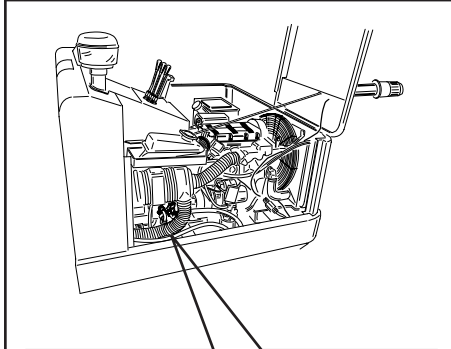

## 2. PREPARAZIONE

La macchina giunge imballata su pallet, coperta da telo in plastica. (Fig.1)



**Peso e dimensioni della macchina sono ripetute nel capitolo CARATTERISTICHE TECNICHE.**

### ATTENZIONE:

Munirsi di guanti, n. 1 chiave a brugola da 5 mm. Tronchesi per acciaio.



Dopo aver tolto l'imballo occorre:

- 1) Togliere il tassello dalla ruota posteriore. Fig.1.
  - 2) Nel caso non fosse possibile avviare il motore, per muovere la macchina, è necessario ruotare di 90° la leva posta sopra la pompa a portata variabile Fig.2
- A fine operazione ricordarsi di rialzare la leva.**
- 3) Fare scendere la macchina a marcia indietro con uno scivolo 6 della larghezza adeguata alla macchina ed avente una lunghezza di almeno 60 cm. Vedi Fig.4

## 2. PREPARATION

The sweeper is delivered packed on a pallet and covered with a plastic sheet. (Fig.1)



**The weight and dimensions of the sweeper are given in the TECHNICAL DATA chapter.**

### CAUTION:

Wear gloves and have to 5 mm allen key and clippers for steel.



After removing the packing:

- 1) Remove the insert of the rear wheel. See Fig. 1.
  - 2) If it is not possible to start the engine, to move the machine, you must turn 90° the lever located above the variable displacement pump Fig.2
- When the operation remember to raise the lever.**
- 3) Let the machine go down in reverse through a suitably large chute 6 having a length of at least 60 cm. See Fig. 4.

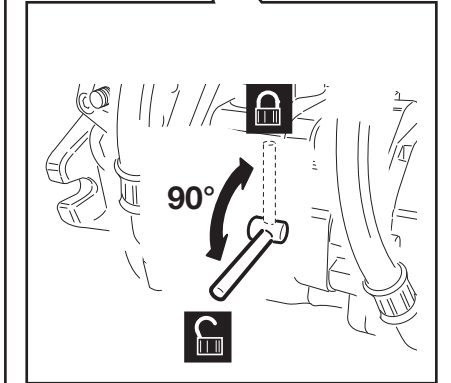

## 3. CONDIZIONI AMBIENTALI CONSENTITE

Valido per modelli funzionanti con motore a batteria:

- Temperatura minima di utilizzo: -20°C(-4°F)
- Temperatura massima di utilizzo: +40°C(+104°F)

## 3. PERMITTED ENVIRONMENTAL CONDITIONS

Applicable for battery-powered models:

- Minimum operating temperature: -20°C (-4°F)
- Maximum operating temperature: +40°C (+104°F)

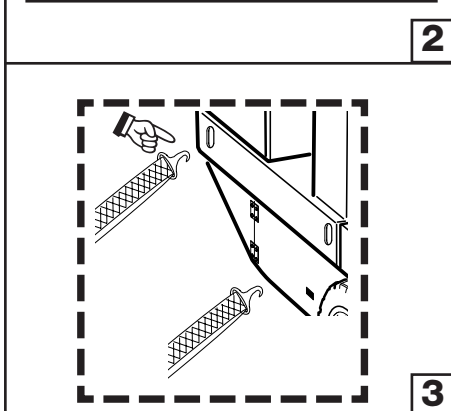

**ATTENZIONE: NON UTILIZZARE E NON LASCIARE IN SOSTA CON TEMPERATURE AL DI SOPRA DI 45°C (+113°F)**



**ATTENTION: NEVER USE OR PARK THE SWEEPER IN THE CASE OF TEMPERATURES ABOVE + 45°C (+113°F)**



## 1. INTRODUCTION

**ATTENTION:** Avant d'utiliser la machine, lire attentivement ce manuel d'instructions.



N.B: Tous les instruments qui se rendront nécessaires pour la protection personnelle de l'utilisateur, par exemple: gants, masques pour éviter l'inhalation de poussières nuisibles, lunettes à lentilles blanches, clés et outils pour effectuer des réglages ou remplacements en général sont à fournir par l'utilisateur.

## 1. EINLEITUNG

**VORSICHT:** Vor dem Gebrauch der Maschine, lesen Sie diese Betriebsanleitung sorgfältig durch.



N.B: Im allegeionen sind alle Geräte, die als nötig für den persönlichen Schutz des Benutzers betrachtet werden, wie z.B. Handschuhe, Staub-Schutzmasken, Schutzbrillen mit weissen Linsen, Schlüssel zur Verstellung oder Ersetzung der Werkzeuge, kundenseitig zu versorgen .

## 1. INTRODUCCIÓN

**ATENCIÓN:** Antes que utilize la máquina lea atentamente este manual de instrucciones.



N.B: Todos los instrumentos que se considerarán necesarios para la protección personal del usuario, por ejemplo guantes, máscaras para evitar de inhalar polvos nocivos, gafas con lentillas blancas, llaves y herramientas para ejecutar regulaciones o remplazos en general debrán ser suministradas por el usuario.

## 2. PRÉPARATION

La machine parvient emballée sur palette, couverte par une toile en plastique. (Fig.1)



**Poids et dimensions de la machine sont répétés au chapitre DONNEES TECHNIQUES.**

### **ATTENTION:**

Se munir de gants, 1 clé allen de 5 mm. Pincers pour couper l'acier.



Après avoir enlevé l'emballage, il faut:

1) Ôter la cheville de la roue arrière. Voir Fig. 1.

2) Si il est pas possible de démarrer le moteur, de déplacer la machine, vous devez activer 90° le levier situé au-dessus de la pompe à cylindrée variable Fig.2

**Lorsque l'opération rappelez-vous de soulever le levier.**

3) Faire descendre la machine à marche arrière à l'aide d'une goulotte ayant une largeur conforme à la machine et una longueur d'au moins **60 cm**. Voir Fig. 4.

## 2. VORBEREITUNG

Die Maschine wird mit einem Plastikfolie geschützt. (Fig.1)



**Gewicht und Abmessungen der Maschine finden Sie im Kapitel TECHNISCHE DATEN.**

### **VORSICHT:**

Rüsten Sie sich mit Hand-Allen-Schlüssel und einem Hammer aus.



Nachden Sie die Verpackung entfernt haben, müssen Sie:

1)den Holzdübel am hinteren Rad entfernen. Abb. 1.

2) Wenn es nicht möglich ist, den Motor zu starten, um die Maschine zu bewegen, müssen Sie 90° des Hebels über der Verstellpumpe Abb.2 befindet schalten **Wenn der Vorgang erinnern, um den Hebel zu erhöhen.**

3) Die Maschine rückwärts durch eine Rutsche sinken lassen. Die Rutsche soll eine der Maschine geeignete Breite sowie auch eine Länge von mindestens **60 cm** haben. Abb. 4.

## 2. PREPARACIÓN

La máquina llega embalada sobre paleta, cubierta por hoja en plástico. (Fig.1)



**Peso y medidas de la máquina están repetidas en el capítulo DATOS TÉCNICOS.**

### **ATENCIÓN:**

Llevar guantes, 1 llave Allen de 5 mm. Alicates para acero.



Despues de quitado el embalaje, hay que: 1) Quitar la cuña de la rueda trasera. Vease Fig. 1

2) Si no es posible poner en marcha el motor, para mover la máquina, debe girar 90° la palanca situada encima de la bomba de caudal variable Fig.2

**Cuando la operación recuerde levante la palanca.**

3) Bajar la máquina marcha atrás por medio de un tobogán de la anchura adecuada a la máquina y de una longitud de al menos **60 cm**. Vease Fig. 4.

## 3. CONDITIONS ENVIRONNEMENTALES PERMISES

**Valable pour modèles à batterie:**

- Température min. d'utilisation: -20°C (-4°F)
- Température max. d'utilisation : +40°C (+104°F)

**ATTENTION: NE PAS UTILISER ET NE PAS STATIONNER SI LA TEMPÉRATURE SUPÈRE LES + 45 °C (+ 113 °F).**



## 3. ZUGELASSENE UMWELTBEDINGUNGEN

**Für batteriebetriebene Modellen:**

- Mindestbetriebstemperatur: -20°C (-4°F)
- Höchstbetriebstemperatur: +40°C (+104°F)

**WICHTIG: NICHT BENUTZEN UND NICHT PARKIEREN, WENN DIE TEMPERATUR HÖHER + 45 °C (+ 113 °F).**



## 3. CONDICIONES AMBIENTALES PERMITIDAS

**Válido para modelos a batería:**

- Temperatura mín. de utilización: -20°C (-4°F)
- Temperatura máx. de utilización : +40°C (+104°F)

**ATENCIÓN: NO UTILICE Y NO DEJE APARCADO CON TEMPERATURAS ARRIBA DE LOS + 45 °C (+ 113 °F).**



#### 4. CONDIZIONI DI UTILIZZO

##### CONDIZIONI DI UTILIZZO CONSENTITE

- La motospazzatrice **160 DK** può essere utilizzata per pulire residui di lavorazione, polvere e sporczia in genere, tutte le superfici in piano, dure, non eccessivamente sconnesse come: cemento, asfalto, gres, ceramica, legno, lamiera, marmo, tappeti in gomma o in materiali plastici in genere, bugnati o lisci, moquettes sintetiche o di fibra a pelo raso, in ambienti chiusi o all'aperto.

##### CONDIZIONI DI UTILIZZO NON CONSENTITE

- La motospazzatrice **160 DK** non può essere usata in pendenze superiori al 18%.
- Non può essere usata con il contenitore sollevato oltre la pendenza del 2%.
- Non può essere usata in ambienti dove sono presenti materiali esplosivi o infiammabili.
- Non può essere usate su superfici sterrate, ghiaiate, o molto sconnesse.
- Non può raccogliere olii, veleni, e materiali chimici in genere, (dovendo usare la macchina in stabilimenti chimici richiedere specifico nulla osta che sarà prodotto dal rivenditore o dalla casa madre).
- Non può essere usata in strade urbane, extraurbane, non può circolare per qualsiasi strada pubblica.
- Non può essere trainata in nessun modo, ne in luoghi privati, ne tantomeno in strade o luoghi pubblici. Non può essere usata per spazzare neve, non può essere utilizzata per lavare o sgassare superfici in genere, bagnate o molto umide.
- Non può operare all'interno di filature o costruzione di materie filiformi, perché la natura del materiale da raccogliere è incompatibile con la rotazione delle spazzole.
- Non possono essere utilizzate in alcun modo da appoggio per cose, o per servirsene come piano rialzato per cose e persone.

#### 4. CONDITIONS OF USE

##### PERMISSIBLE CONDITIONS OF USE

- The motorsweeper **160 DK** can be used for cleaning from work wastes, dust and dirt in general, all flat and hard surfaces, provided they are not too much undulated, such as: concrete, asphalt, gres, ceramic, wood, metal sheet, marble, carpets in rubber or in plastic material in general, rusticated or smooth, synthetic or fiber moquettes with short hair, in closed or outdoor environments.

##### NON-PERMISSIBLE CONDITIONS OF USE

- The motorsweeper **160 DK** cannot be used on slopes higher than 18%.
- Cannot be used with lifted container on slopes higher than 2 %.
- Cannot be used in environments where explosive or inflammable materials are stored.
- Cannot be used on dirt, gravelly or very rough grounds.
- Cannot collect oil, poison and chemical materials in general, (if the machine must be used inside chemical plants ask for the specific permission which will be issued by the reseller or manufacturer).
- Cannot be used in urban or suburban roads and cannot be driven on any public road.
- Cannot be towed in any way, neither in private places, nor least of all in public roads or places. Cannot be used for wiping snow, cannot be used for washing or taking the grease off surfaces in general, wet or very moist surfaces.
- Cannot operate inside spinning mills or thread-like producing factories, because the nature of the material to be collected is incompatible with the the rotating brushes.
- Cannot be used in any way as a rest for things or as an elevated surface for things and persons.

#### 4. CONDITIONS D'UTILISATION

##### CONDITIONS D'UTILISATION PERMISES

- La balayeuse **160 DK** peut être utilisée pour nettoyer, déchets d'usinage, poussière et saleté en général, toutes les surfaces plates, dures, non excessivement disjointes comme: béton, asphalte, grès, ceramica, faïence, bois, tôle, marbre, tapis en caoutchouc ou en matières plastiques en général, bossées ou lisses, moquettes synthétiques ou de fibre à poil rasé, en ambiances fermées ou à l'extérieur.

##### CONDITIONS D'UTILISATION NON PERMISES

- La balayeuse **160 DK** ne peut pas être utilisée sur des pentes supérieures à 18%.
- Ne peut pas être utilisée avec le conteneur soulevé au delà d'une pente de 2 %.
- Ne peut pas être utilisée dans des milieux où il y a des matières explosives ou inflammables.
- Ne peut pas être utilisée sur des surfaces sans macadam, couvertes de gravier, ou très disjointes.
- Ne peut pas ramasser de l'huile, du poison, et des matières chimiques en général, (si la machine doit être utilisée dans des établissements chimiques, il faut demander une autorisation spécifique qui sera produite par le revendeur ou par la maison constructrice).
- Ne peut pas être utilisée sur des routes urbaines, extraurbaines, ne peut pas circuler sur n'importe quelle route publique.
- Ne peut pas être entraînée en aucune façon, ni dans des lieux privés, ni d'autant moins sur des routes ou lieux publiques. Ne peut pas être utilisée pour balayer la neige, ne peut pas être utilisée pour laver ou dégraisser des surfaces en général, mouillées ou très humides.
- Ne peut pas opérer à l'intérieur de filatures ou d'usines produisant des matières filiformes, car la nature du matériel à ramasser est incompatible avec la rotation des brosses.
- Ne peut pas être utilisée en aucune façon comme un appui pour les choses, ou comme une surface relevée pour choses et personnes.

#### 4. BETRIEBSBEDINGUNGEN

##### ZUGELASSENE BETRIEBSBEDINGUNGEN

- Die Kehrmaschine **160 DK** kann gebraucht werden, um das foldende sauberzumachen: Bearbeitungsrückstände, Staub und Dreck im allgemeinen, alle Oberflächen, vorausgesetzt diese hart, flach, nicht zu viel unzusammenhängend sind, wie: Beton, Asphalt, Gres, Fliesen, Holz, Blech, Marmor, Teppiche aus Gummi oder Kunststoff im allgemeinen, genockt oder glatt, Teppichboden syntetisch oder aus kurzhaarigen Fasern, drinnen oder drinnen.

##### NICHT ZUGELASSENE BETRIEBSBEDINGUNGEN

- Die Kehrmaschine **160 DK** muß nicht benutzt werden, wenn die Grundneigung höher als 18% ist.
- muß nicht benutzt werden, wenn der Behälter über 2 % geneigt ist.
- muß nicht in Umgebungen, wo Explosivstoffe und/oder Zündstoffe gelagert sind, benutzt werden.
- muß nicht auf abgetragenen, nicht asphaltierten oder sehr unzusammenhängenden Oberflächen benutzt werden.
- kann nicht das folgende sammeln: Öl, Gift, und Chemikalien im allgemeinen, (braucht man die Maschine für Chemiewerke, muß man eine besondere Genehmigung haben, welche vom Wiederverkäufer oder Hersteller ausgestellt wird).
- muß nicht auf Stadt- und Landstraßen benutzt werden. Sie darf nicht auf öffentlichen Straßen fahren.
- muß auf keinen Fall nicht geschleppt werden, weder auf Privatorten, noch auf öffentlichen Orten. Sie muß nicht gebraucht werden, um Schnee zu kehren, um Oberflächen zu waschen oder entfetten, wenn diese naß oder sehr feucht sind.
- muß nicht in Garn-, Faden- oder Drahtfabriken operieren, weil die Natur der kehrenden Stoffe unvereinbar mit der Rotation der Bürsten ist.
- muß nicht als Stützpunkt oder Stellfläche für Sachen oder Personen gebraucht werden.

#### 4. CONDICIONES DE UTILIZACIÓN

##### CONDICIONES DE UTILIZACIÓN PERMITIDAS

- La **barredora 160 DK** puede ser utilizada para limpiar residuos de elaboración, polvo y suciedad en general, todas las superficies horizontales, duras, no demasiado desconectadas como: cemento, asfalto, gres, cerámica, madera, chapa, mármol, tapetes de goma o de materiales plásticos en general, almohadillados o lisos, moquetas sintéticas o de fibra de pelo raso, en ambientes cerrados o al aire libre.

##### CONDICIONES DE UTILIZACIÓN NO PERMITIDAS

- La motobarredora **160 DK** no puede ser utilizada en pendientes superiores al 18%.
- No puede ser utilizada con el contenedor levantado más allá de la inclinación del 2%.
- No puede ser utilizada en ambientes donde se encuentran materiales explosivos o inflamables.
- No puede ser utilizada en superficies desmontadas, guijosas, o muy desconectadas.
- No puede recoger aceites, venenos o materiales químicos en general, (si hay que utilizar la máquina en establecimientos químicos es preciso tener la autorización emitida por el revendedor o por la casa madre).
- No puede ser utilizada en carreteras urbanas, extraurbanas, no puede circular en ninguna carretera pública.
- No puede ser remolcada de ninguna manera, ni en lugares privados, ni cuanto menos en carreteras o lugares públicos. No puede ser utilizada para barrer la nieve, no puede ser utilizada para lavar o desgrasar superficies en general, mojadas o muy húmedas.
- No puede operar al interior de hilaturas o construcción de materias filiformes, porque la naturaleza del material que hay que recoger es incompatible con la rotación de los cepillos.
- No puede ser utilizada de ninguna manera como apoyo para cosas, o como plano elevado para cosas y personas.

**5. CARATTERISTICHE TECNICHE  
DI IDENTIFICAZIONE  
DELLA MACCHINA**

**5. TECHNICAL PARTICULARS  
AND MACHINE IDENTIFICATION**

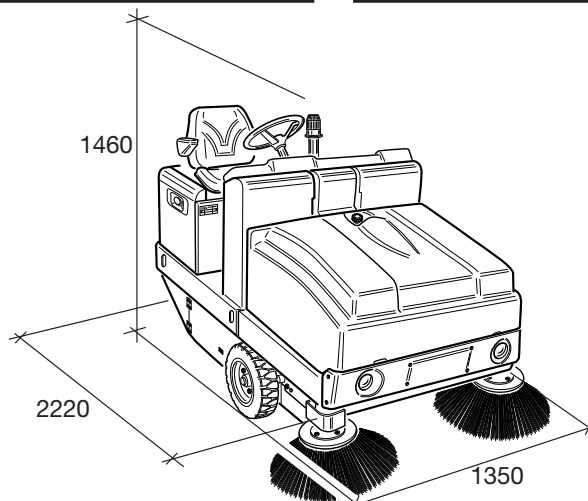

**160 DK**

1000  
1300  
1600  
11.500  
18  
SI-YES  
9,5  
16,5  
12/250  
12/100  
12V/60A  
7,8  
300  
1.350  
2.220  
1.460  
1.256  
81,1  
3  
98,5  
< 2,5  
< 0,5

**MODELLO**

Larghezza max. di pulizia con la sola spazzola centrale mm  
Larghezza max. di pulizia con spazzola centrale + n. 1 laterale mm  
Larghezza max. di pulizia con spazzola centrale + n. 2 laterale mm  
Massima capacità di pulizia teorica m<sup>2</sup>/h  
Pendenza massima superabile %  
Trazione idrostatica sulla ruota posteriore  
Velocità massima Km/h  
Potenza motore diesel Kubota a 2400 g/m KW  
Potenza motore ventola V/Watt  
Potenza motore scuotifiltro V/Watt  
Batterie V-A/h  
Filtro in tessuto m<sup>2</sup>  
Capacità contenitore (teorica) Lt.  
Larghezza massima senza spazzole mm.  
Lunghezza massima senza spazzole mm.  
Altezza massima mm.  
Massa (GVW) Kg.  
Pressione acustica L<sub>PA</sub> dB(A)  
Dubbio K<sub>PA</sub> dB(A)  
Pressione acustica L<sub>WA</sub> + Dubbio K<sub>WA</sub>  
Livello di vibrazioni mano-braccio m/s<sup>2</sup>  
Livello di vibrazione corpo m/s<sup>2</sup>

**MODEL**

Max. sweeping width with just the central brush mm  
Max. sweeping width with central brush + 1 side one mm  
Max. sweeping width with central brush + 2 side one mm  
Maximum theoretical sweeping capacity m<sup>2</sup>/h  
Maximum permissible gradient %  
Rear wheel drive  
Max. speed Km/h  
Kubota diesel motor power at 2400 rpm KW  
Fan motor power  
Filter shaking motor power V/Watt  
Batteries V-A/h  
Filter in fabric m<sup>2</sup>  
Container capacity (theoretical) Lt.  
Max. width without brushes mm.  
Max. length without brushes mm.  
Max. height mm.  
Gross vehicle weight (GVW) Kg.  
Sound pressure level L<sub>PA</sub> dB(A)  
Uncertainty K<sub>PA</sub> dB(A)  
Sound pressure level L<sub>WA</sub> + Uncertainty K<sub>WA</sub>  
Hand-arm vibration level m/s<sup>2</sup>  
Body vibration m/s<sup>2</sup>



**5. CARACTERISTIQUES  
TECHNIQUES D'IDENTIFICATION  
DE LA MAQUINE**

**5. TECHNISCHE MERKMALE UND  
IDENTIFICATION DER  
MARKIERUNG**

**5. CARACTERÍSTICAS TÉCNICAS  
DE IDENTIFICACIÓN  
DE LA MÁQUINA**

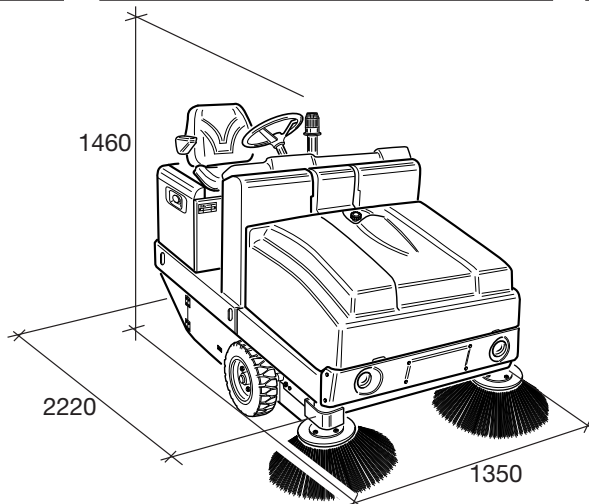

**MODÈLE**

Largeur max. de nettoyage avec la seule brosse centrale mm.  
 Largeur max. de nettoyage avec 1 brosse centrale + 1 latérale mm.  
 Largeur max. de nettoyage avec 1 brosse centrale + 2 latérale mm.  
 Max. capacité nettoyage théorique m<sup>2</sup>/h  
 Pente max. superable %  
 Traction sur la roue arrière  
 Vitesse maximum Km/h  
 Puissance moteur Diesel Kubota à 2400 g/m - Kw  
 Puissance moteur ventilateur V/Watt  
 Puissance moteur secoueur de filtre V/Watt  
 Batterie V-A/h  
 Filtre en tissu m<sup>2</sup>  
 Capacité conteneur (théorique) Lt.  
 Largeur maximum sans brosses mm.  
 Longueur maximum sans brosses mm.  
 Hauteur maximum mm.  
 Masse (GVW) Kg.  
 Niveau de pression acoustique L<sub>pA</sub> dB(A)  
 Incertitude dB(A)  
 Niveau de pression acoustique L<sub>WA</sub> + Incertitude K<sub>WA</sub>  
 Niveau de vibrations main-bras m/s<sup>2</sup>  
 Vibrations corps entier m/s<sup>2</sup>

**MODELL**

Max. Kkehrbreite nur mit Hauptbürste mm.  
 Max. Kkehrbreite mit Hauptbürste + 1 Stk. Seitenbürste mm.  
 Max. Kkehrbreite mit Hauptbürste + 2 Stk. Seitenbürste mm.  
 Max. theoretische Kkehrkapazität m<sup>2</sup>/h  
 Max. zugelassene Neigung %  
 Hydrostatischer Antrieb am hinteren Rad  
 Höchste Geschwindigkeit Km/h  
 Leistung mit Kubota Diesel-Motor 2400 UPM - Kw  
 Stärke des Motorlüfters V/Watt  
 Stärke des Filterschüttelmotors V/Watt  
 Batterien V-A/h  
 Filter aus Gewebe m<sup>2</sup>  
 Kapazität des Behälters (theoretisch) Lt.  
 Max. Länge ohne Bürsten mm.  
 Max. Breite ohne Bürsten mm.  
 Max. Höhe mm.  
 Masse (GVW) Kg.  
 Schalldruckpegel L<sub>pA</sub> dB(A)  
 Unsicherheit dB(A)  
 Schalldruckpegel L<sub>WA</sub> + Unsicherheit K<sub>WA</sub>  
 Hand/Arm-Vibrationspegel m/s<sup>2</sup>  
 Körpervibrationen m/s<sup>2</sup>

**MODELO**

Ancho max. de limpieza con el sola cepillo central mm.  
 Ancho max. de limpieza con cepillo central + 1 lateral mm.  
 Ancho max. de limpieza con cepillo central + 2 lateral mm.  
 Máxima capacidad de limpieza teórica m<sup>2</sup>/h  
 Pendiente máximo superable %  
 Tracción en la rueda trasera  
 Velocidad máx. Km/h  
 Potencia motor diesel Kubota a 2400 g/m - Kw  
 Potencia motor ventilador V/ Watt  
 Potencia motor sacudidor V/ Watt  
 Batería V-A/h  
 Filtro en tejido m<sup>2</sup>  
 Capacidad contenedor (teórica) Lt.  
 Ancho máximo sin cepillos mm.  
 Longitud máxima sin cepillos mm.  
 Altura máxima mm.  
 Masa (GVW) Kg.  
 Nivel depresión sonora L<sub>pA</sub> dB(A)  
 Inseguridad dB(A)  
 Nivel de presión sonora L<sub>WA</sub> + Inseguridad K<sub>WA</sub>  
 Nivel de vibraciones mano-brazo m/s<sup>2</sup>  
 Vibraciones cuerpo m/s<sup>2</sup>

## 6. DESCRIZIONE DELLA MACCHINA

- 1 Telaio
- 2 Carter laterale dx
- 3 Cofano posteriore
- 4 Contenitore
- 5 Cofano contenitore
- 6 Sedile
- 7 Lampeggiante
- 8 Volante
- 9 Ruota anteriore
- 10 Paraurto
- 11 Fanali anteriori
- 12 Pedale avanzamento
- 13 Pedale freno di servizio
- 14 Leva freno di stazionamento
- 15 Spazzola laterale
- 16 Motore idraulico spazzola laterale
- 17 Leva acceleratore
- 18 Leva distributore
- 19 Chiave avviamento
- 20 Pulsanti
- 21 Strumento multifunzione
- 22 Mostrina interruttori e spie
- 23 Descrizione comandi
- 24 Porta fusibili
- 25 Identificazione macchina
- 26 Deviatore comando spazzola laterale
- 27 Motore endotermico
- 28 Filtro aria motore endotermico
- 29 Filtro nafta motore endotermico
- 30 Serbatoio gasolio
- 31 Indicatore livello carburante
- 32 Serbatoio olio
- 33 Indicatore ottico di livello
- 34 Batteria - Avviamento
- 36 Pompa a portata variabile
- 37 Motore idraulico
- 38 Ruota posteriore
- 39 Chiave apertura cofani laterali
- 40 Coperchio contenitore
- 41 Filtri in tessuto
- 42 Filtri olio idraulico
- 43 Convogliatore ventola aspirazione
- 44 Motore per ventola aspirazione 12V
- 45 Spazzola centrale
- 46 Supporto mobile spazzola centrale
- 47 Fermo per supporto mobile
- 48 Guarnizione laterale
- 49 Fermo per guarnizione laterale
- 50 Cicalino retromarcia 12V
- 51 Fanale posteriore
- 52 Manicotto filtro aria
- 53 Tappo serbatoio olio
- 54 Tappo serbatoio gasolio
- 59 Supporto per scuotifiltro
- 60 Fermo per scuotifiltro
- 61 Fermo per motore scuotifiltro
- 62 Scuotifiltro 12 V

## 6. DESCRIPTION OF THE MACHINE

- 1 Frame
- 2 RH carter
- 3 Rear bonnet
- 4 Container
- 5 Container bonnet
- 6 Seat
- 7 Flashing light
- 8 Steering wheel
- 9 Front wheel
- 10 Bumper
- 11 Front light
- 12 Driving pedal
- 13 Work brake pedal
- 14 Parking brake lever
- 15 Lateral brush
- 16 Lateral brush hydraulic motor
- 17 Accelerator lever
- 18 Distributor lever
- 19 Ignition key
- 20 Buttons
- 21 Multifunction tool
- 22 Switches and lights badge
- 23 Controls description
- 24 Fuse holder
- 25 Machine identification
- 26 Lateral brush control switch
- 27 Endothermal motor
- 28 Endothermal motor air filter
- 29 Endothermal motor gasoil filter
- 30 Gasoil tank
- 31 Fuel level indicator
- 32 Oil tank
- 33 Optical level indicator
- 34 Battery
- 36 Variable capacity pump
- 37 Hydraulic motor
- 38 Rear wheel
- 39 Wrench for opening side bonnets
- 40 Container lid
- 41 Filters in fabric
- 42 Hydraulic oil filters
- 43 Suction fan conveyor
- 44 Suction fan motor 12V
- 45 Central brush
- 46 Central brush mobile bracket
- 47 Stop for mobile bracket
- 48 Lateral seal
- 49 Stop for lateral seal
- 50 Reverse gear buzzer
- 51 Rear light
- 52 Air filter sleeve
- 53 Oil tank cap
- 54 Gasoil tank cap
- 59 Filter shaker bracket
- 60 Filter shaker stop
- 61 Fermo per motore filter shaker
- 62 Filter shaker 12 V

## 6. DESCRIPTION DE LA MACHINE

- 1 Châssis
- 2 Carter latéral droit
- 3 Capot arrière
- 4 Conteneur
- 5 Capot conteneur
- 6 Siège
- 7 Feu clignotant
- 8 Volant
- 9 Roue antérieure
- 10 Pare-chocs
- 11 Feux antérieurs
- 12 Pédale de marche
- 13 Pédale frein de service
- 14 Levier frein de stationnement
- 15 Brosse latérale
- 16 Moteur hydraulique brosse latérale
- 17 Levier accélérateur
- 18 Levier distributeur
- 19 Clé d'allumage
- 20 Bouton
- 21 Outil multifonction
- 22 Panneau interrupteurs et témoins
- 23 Description commandes
- 24 Porte-fusibles
- 25 Identification machine
- 26 Commutateur commande brosse latérale
- 27 Moteur endothermique
- 28 Filtre air moteur endothermique
- 29 Filtre nafta moteur endothermique
- 30 Réservoir gasoil
- 31 Indicateur niveau carburant
- 32 Réservoir huile
- 33 Indicateur optique de niveau
- 34 Batterie démarrage
- 36 Pompe à débit variable
- 37 Moteur hydraulique
- 38 Roue arrière
- 39 Clé ouverture capots latéraux
- 40 Couvercle conteneur
- 41 Filtres en tissu
- 42 Filtres huile hydraulique
- 43 Convoyeur ventilateur aspiration
- 44 Moteur pour ventilateur aspiration 12V
- 45 Brosse centrale
- 46 Support mobile brosse centrale
- 47 Arrêt pour support mobile
- 48 Joint latéral
- 49 Arrêt pour joint latéral
- 50 Buzzer marche arrière 12V
- 51 Feu arrière
- 52 Manchon filtre air
- 53 Bouchon réservoir huile
- 54 Tappo réservoir gasoil
- 59 Support pour secoueur de filtre
- 60 Arrêt pour secoueur de filtre
- 61 Convoyeur pour moteur secoueur de filtre
- 62 Secoueur de filtre 12 V

## 6. BESCHREIBUNG DER MASCHINE

- 1 Fahrgestell
- 2 Rechte carter
- 3 Heckklappe
- 4 Behälter
- 5 Behälterklappe
- 6 Sitz
- 7 Blinklicht
- 8 Lenkrad
- 9 Vorderes Rad
- 10 Stoßstange
- 11 Scheinwerfer
- 12 Fahrpedal
- 13 Bremspedal
- 14 Hebel der Handbremse
- 15 Seitenbürste
- 16 Seitenbürste-Hydraulikmotor
- 17 Gashebel
- 18 Verteilerhebel
- 19 Zündschlüssel
- 20 Hupeknopf
- 21 Multifunktionswerkzeug
- 22 Schaltplatte und Anzeiger
- 23 Steuerungsbeschreibung
- 24 Sicherungsträger
- 25 Identifikation der Maschine
- 26 Seitenbürste-Wechselschalter
- 27 Dieselmotor
- 28 Dieselmotor-Luftfilter
- 29 Dieselmotor-Kraftstofffilter
- 30 Kraftstoffbehälter
- 31 Kraftstoffanzeiger
- 32 Ölbehälter
- 33 Optischer Standanzeiger
- 34 Startatterie
- 36 Verstellpumpe
- 37 Hydromotor
- 38 Hinteres Rad
- 39 Schlüssel für seitliche Hauben
- 40 Behälterdecke
- 41 Filter aus Gewebe
- 42 Hydraulischer Ölfilter
- 43 Absauglüfter-Förderer
- 44 Absauglüfter-Motor12V
- 45 Hauptbürste
- 46 Bewegliche Halterung der Hauptbürste
- 47 Sperre der beweglichen Halterung
- 48 Seitliche Dichtung
- 49 Sperre der seitlichen Dichtung
- 50 Rückfahrsummer
- 51 Rückfahrleuchte
- 52 Luftfilterhülse
- 53 Ölbehälterdeckel
- 54 Kraftstoffbehälterdeckel
- 59 Filterschüttlerträger
- 60 Filterschüttlersperrung
- 61 Sperrung für Filterschüttlermotor
- 62 Filterschüttler 12 V

## 6. DESCRIPCIÓN DE LA MÁQUINA

- 1 Bastidor
- 2 Carter lateral derecho
- 3 Capó trasero
- 4 Contenedor
- 5 Capó contenedor
- 6 Asiento
- 7 Intermitente
- 8 Volante
- 9 Rueda delantera
- 10 Parachoques
- 11 Faroles delanteros
- 12 Pedal de avance
- 13 Pedal freno de servicio
- 14 Leva freno de estacionamiento
- 15 Cepillo lateral
- 16 Motor hidráulico cepillo lateral
- 17 Leva acelerador
- 18 Leva distribuidor
- 19 LLave de puesta en marcha
- 20 Botones
- 21 Instrumento multifunción
- 22 Panel interruptores y testigos
- 23 Descripción mandos
- 24 Porta-fusibles
- 25 Identificación máquina
- 26 Desviador mando cepillo lateral
- 27 Motor endotérmico
- 28 Filtro aire motor endotérmico
- 29 Filtro nafta motor endotérmico
- 30 Depósito gasoleo
- 31 Indicador nivel carburante
- 32 Depósito aceite
- 33 Indicador óptico de nivel
- 34 Batería - Puesta en marcha
- 36 Bomba de caudal variable
- 37 Motor hidráulico
- 38 Rueda trasera
- 39 Llave abertura capós laterales
- 40 Capa contenedor
- 41 Filtros en tejido
- 42 Filtros aceite hidráulico
- 43 Encanalador ventilador aspiración
- 44 Motor para ventilador aspiración 12V
- 45 Cepillo central
- 46 Soporte móvil cepillo central
- 47 Tope para soporte móvil
- 48 Empaquetadura lateral
- 49 Tope para empaquetadura lateral
- 50 Avisador marcha atrás12V
- 51 Farol trasero
- 52 Manguito filtro aire
- 53 Tapón depósito aceite
- 54 Tapón depósito gasoleo
- 59 Soporte para sacudidor
- 60 Tope para sacudidor
- 61 Tope para motor sacudidor
- 62 Sacudidor12 V

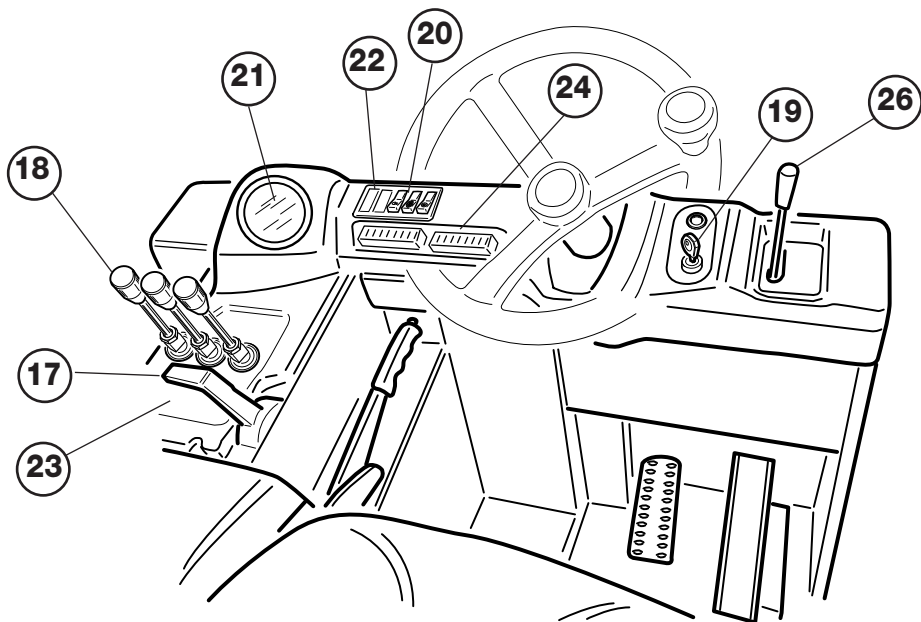
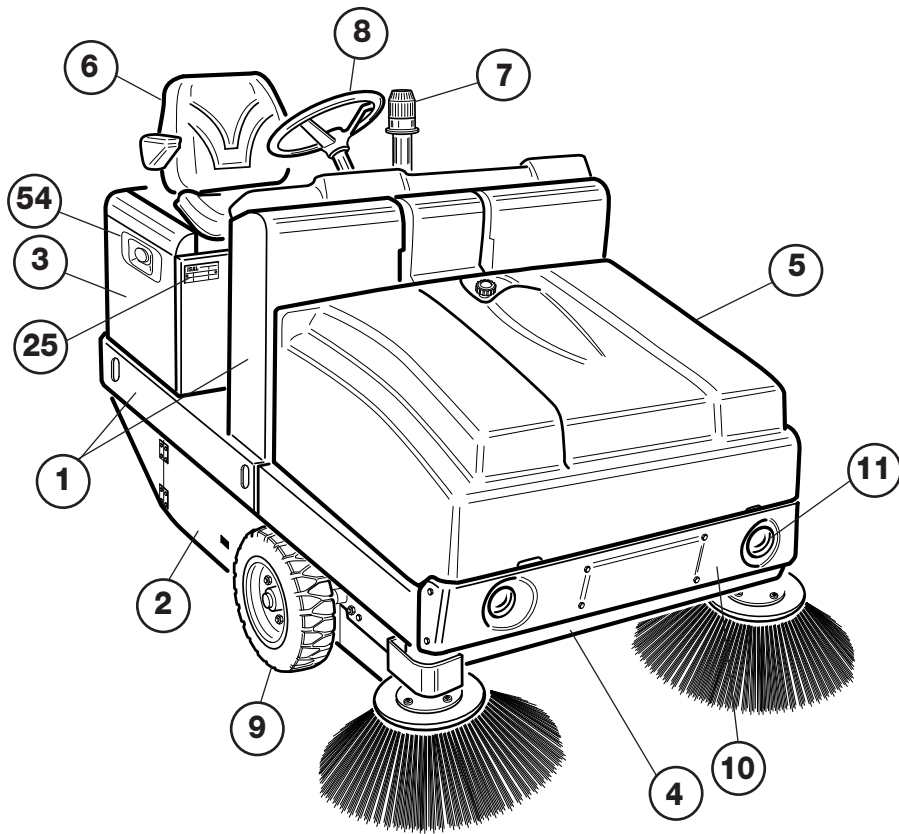
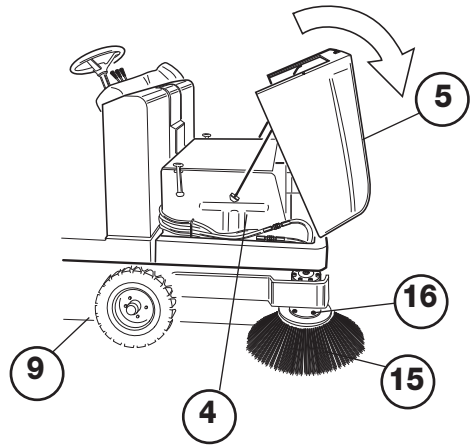
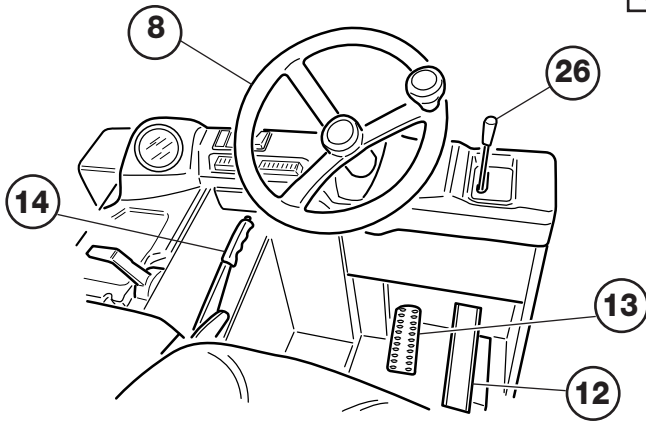

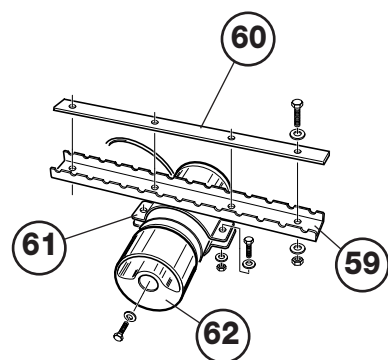
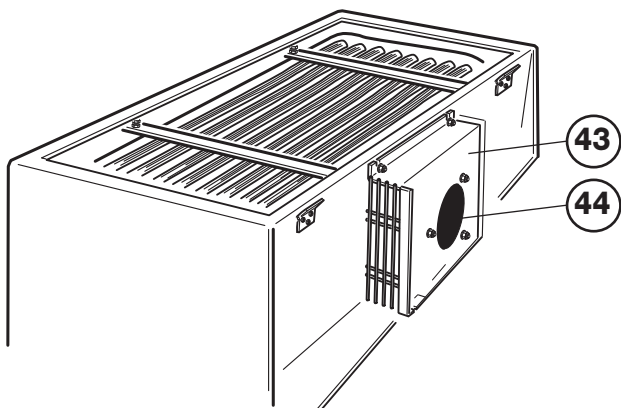
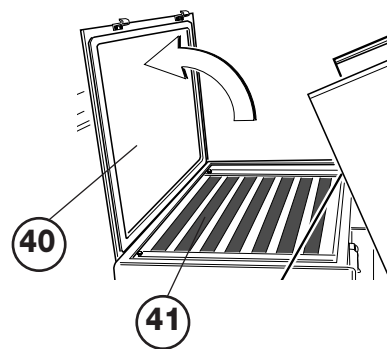
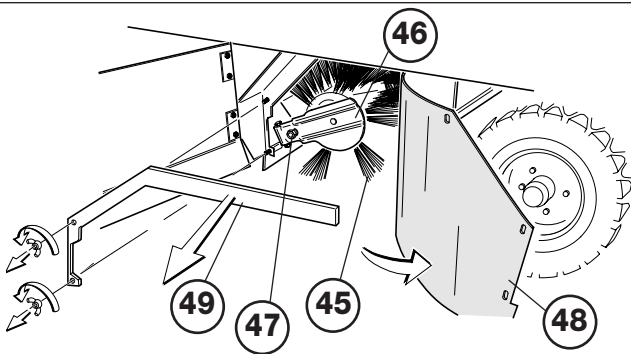
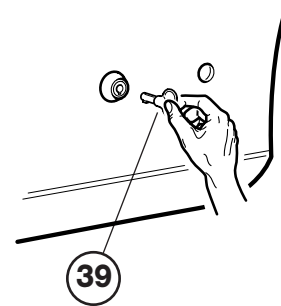
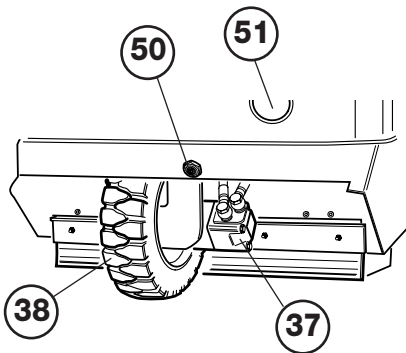
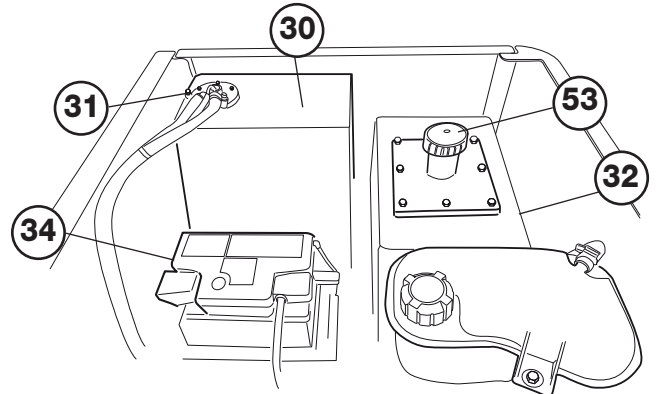
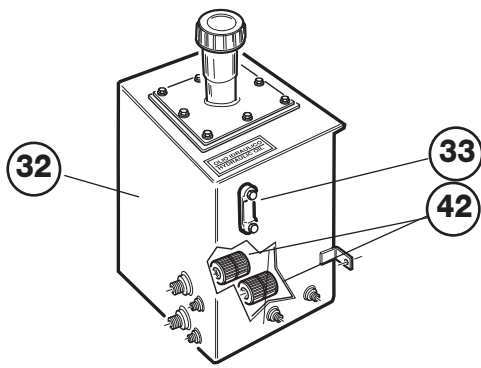
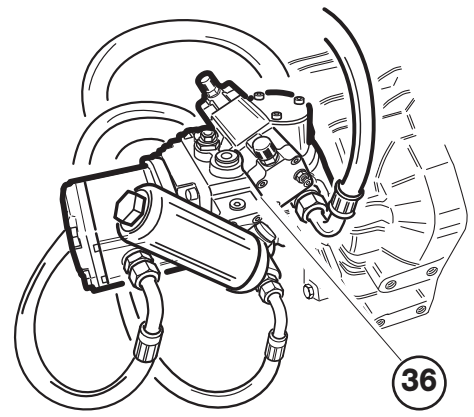
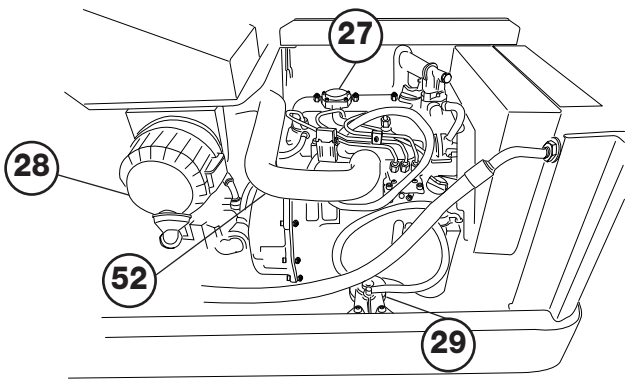

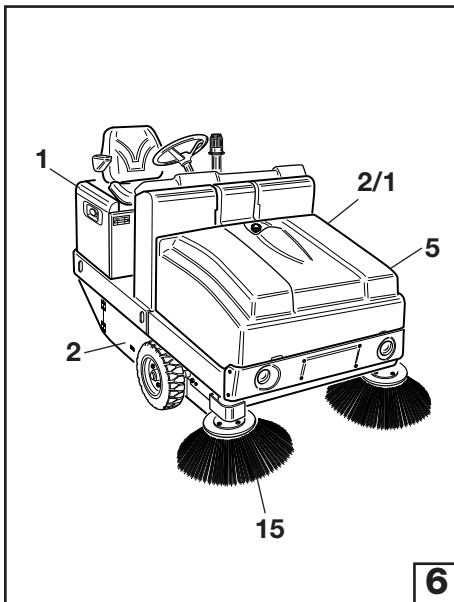

6

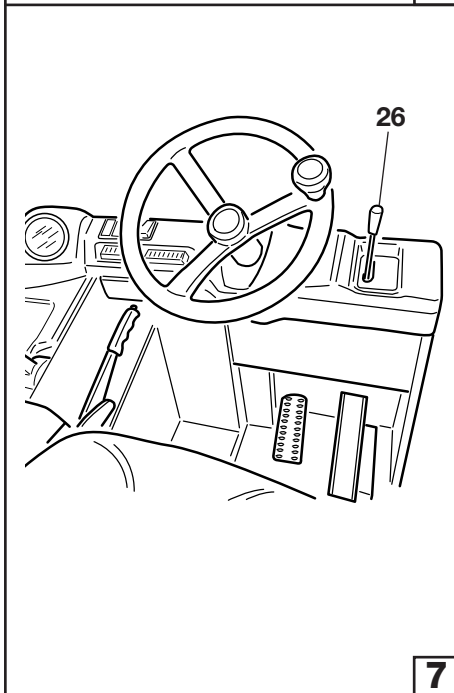

7

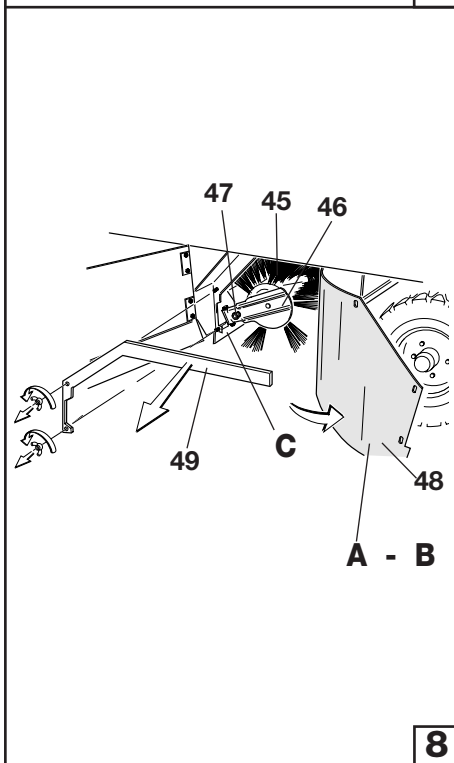

8

## 6. DESCRIZIONE DELLA MACCHINA

### • PROTEZIONI DI SICUREZZA

Come illustrato in Fig. 6 è possibile vedere le protezioni di sicurezza, le quali devono essere accuratamente montate integre. Non è possibile usare la macchina con una o più protezioni mancanti o danneggiate, la descrizione delle protezioni e i rispettivi codici di ordinazione pertanto sono sotto riportati:

PART/TEIL	FIG.	DESCRIZIONE/DESCRIPTION	COD./CODE
1	6	COFANO MOTORE/MOTOR BONNET	
2	6	PROTEZIONE DESTRA/RH SAFETY GUARD	
2/1	6	PROTEZIONE SINISTRA/LH SAFETY GUARD	
5	6	COFANO ANTERIORE/ FRONT BONNET	

### • SPAZZOLA LATERALE

La spazzola laterale, part. 15 Fig. 6, funge da convogliatore della polvere e dei detriti, serve esclusivamente per la pulizia di bordi, angoli, profili, dopo la pulizia dei quali deve essere disinserita (alzandola con l'apposita leva part. 26 Fig. 7) per evitare di sollevare inutile polvere e perchè l'effetto pulito della spazzola laterale è minore di quello ottenuto con la spazzola centrale.

**ATTENZIONE:** Non toccare mai con le mani, durante la rotazione, la spazzola laterale, non raccogliere materiali filacciosi.

### • SPAZZOLA CENTRALE

La spazzola centrale, part. 45 Fig. 8, è l'organo principale della macchina, il quale permette il caricamento della polvere e dei detriti nel cassetto di raccolta; essa può essere richiesta in diverse durezza e natura delle setole, a seconda del tipo di materiale da raccogliere, ed è regolabile in altezza quando si consuma.

**IMPORTANTE:** Non è idonea alla raccolta di corde, fili in genere, reggie per imballi, paglia e fieno, ecc, perchè si avvolgerebbero alle spazzole danneggiandole.

## 6. DESCRIPTION OF THE MACHINE

### • SAFETY GUARDS

As illustrated in Fig. 6 it is possible to see the safety guards which must be carefully mounted in sound condition. The sweeper cannot be used if one or more guards are missing or damaged. A description of these guards and their ordering codes are given below:

### • SIDE BRUSH

The side brush, part 15 Fig. 6, collects dust and dirt and is only used to clean edges, corners and borders. After cleaning it must be deactivated (lifting it with its lever part 26 Fig. 7) to avoid raising dust and because cleaning with the side brush is less effective than with the central one.

**ATTENTION:** Never touch the side brush with your hands while it is rotating. Do not collect thready materials.

### • CENTRAL BRUSH

The central brush, part 45 Fig. 8, is the main component of the sweeper and is used to gather dust and dirt in the collection box; it can be requested with bristles made of different types of material and hardness according to the type of material to be collected. It is height adjustable for when it gets worn.

**IMPORTANT:** Do not collect string, wires, packaging, straps, sticks, etc longer than 25 cm as they could wind around the central and side brushes.

## 6. DESCRIPTION DE LA MACHINE

### • PROTECTIONS DE SÉCURITÉ

Sur la Fig. 6 il est possible de voir les protections de sécurité, qui doivent être soigneusement montées intactes. Il n'est pas possible d'utiliser la machine avec une ou plus protections absentes ou endommagés, voici la description des protections et leurs codes de commande:

TEIL/PC/PZ	ABB./FIG./FIG	DESCRIPTION/BESCHREIBUNG/DESCRIPCION	BESTELL-NR./CODE/CODIGO
1	6	MOTOR BONNET/MOTORKLAPPE/PROTECCIÓN	
2	6	RH SAFETY GUARD/RECHTE/SCHUTZVORRICHTUNG/PROTECCION DE	
2/1	6	LH SAFETY GUARD/LINKE SCHUTZVORRICHTUNG/PROTECCION IZ	
5	6	FRONT BONNET/ VORDERE Klappe/LADO DERECHO	

### • BROSE LATÉRALE

La brosse latérale, part. 15 Fig. 6, sert de convoyeur de poussière et de déchets, sert uniquement pour le nettoyage de bords, coins, profils. Après le nettoyage, elle doit être disinsérée (en la levant par le levier part. 26 Fig. 7) pour éviter de soulever inutilement de la poussière et parce que l'effet nettoyé de la brosse latérale est moins important que celui obtenu avec la brosse centrale.

**ATTENTION: Ne jamais toucher avec les mains, pendant la rotation, la brosse latérale, ne pas ramasser de matières filamenteuses.**

### • BROSE CENTRALE

La brosse centrale, part. 45 Fig. 8, est l'organe principal de la machine, qui permet le chargement de la poussière et des déchets dans le tiroir de ramassage; elle peut être commandée avec différente dureté et nature des soies, selon le type de matériel à ramasser, et elle est réglable en hauteur lorsque elle s'use.

**IMPORTANT: Ne pas ramasser: cordes, fils, feuillards pour emballages, bâtons, etc. plus de 25 cm. en longueur car ils pourraient s'enrouler à la brosse centrale et latérale.**

## 6. BESCHREIBUNG DER MASCHINE

### • SCHUTZVORRICHTUNGEN

Abb. 6 zeigt die Schutzvorrichtungen der Maschine: diese müssen sorgfältig eingebaut werden und unversehrt sein. Es ist nicht möglich, die Maschine mit einem oder mehr fehlenden oder beschädigten Schutzvorrichtungen zu benutzen. Die Beschreibung der Schutzvorrichtungen und deren Bestellkoden sind wie folgt:

### • SEITENBÜRSTE

Die Seitenbürste, Teil 15 Abb. 6 dient als Förderer von Staub und Abfällen aber ausschließlich für das Putzen von Kanten, Ecken und Profilen, nach dem Putzen muß sie entfernt werden (durch den Hebel Teil 26 Abb. 7), um zu vermeiden, das zwecklose Aufheben von Staub und auch weil die Kehrwirkung von der Seitenbürste kleiner als die von der Hauptbürste ist.

**VORSICHT: Nie mit den Händen die rotierende Seitenbürste berühren. Kein fädiges Material sammeln.**

### • HAUPTBÜRSTE

Die Hauptbürste, Teil 45 Abb. 8 ist der Hauptteil der Maschine: sie erlaubt das Sammeln Staub und Abfälle in die Schblade. Man kann die Bürste in verschiedenen Härten und Borsten bestellen, je nach dem Art vom sammelnden Material; sie selbstverstellbar und selbst-nivellierend und braucht keine Regelung.

**WICHTIG : Die Maschine ist nicht tüchtig für das Sammeln von Seilen, Drähten, Kunststoffbändern, Stroh und Heu, usw, weil diese könnten sich um die Bürsten rollen und sie beschädigen.**

## 6. DESCRIPCIÓN DE LA MÁQUINA

### PROTECCIONES DE SEGURIDAD

En Fig. 6 se pueden ver las protecciones de seguridad, que tienen que ser cuidadosamente montadas e íntegras. No se puede utilizar la máquina sin una o más protecciones o que sean dañadas. La descripción de las protecciones y sus códigos de pedido por lo tanto están detallados abajo:

### • CEPILLO LATERAL

El cepillo lateral, part. 15 Fig. 6, sirve de transportador del polvo y de los desechos, sirve exclusivamente para la limpieza de bordes, rincones, perfiles, después de la limpieza tiene que ser desenchufada (levantandola por la leva part. 26 Fig. 7) para evitar que se levante inutil polvo y porque el efecto limpieza del cepillo lateral es menor de lo que se alcanza con el cepillo central.

**ATENCIÓN: Nunca toque con las manos, durante la rotación, el cepillo lateral, no recolecte materiales filamentosos.**

### • CEPILLO CENTRAL

El cepillo central, part. 45 Fig. 8, es el órgano principal de la máquina, que permite la carga del polvo y de los desechos en el cajón de recogida; se puede pedir en varias durezas y tipos de cerdas, según el tipo de material que hay que recolectar, y está ajustable en altura cuando se consume.

**IMPORTANTE: No recolecte cuerdas, hilos, cintas de embalajes, palos, etc largos más de 25 cm. porque podrían enrollarse al cepillo central y lateral.**

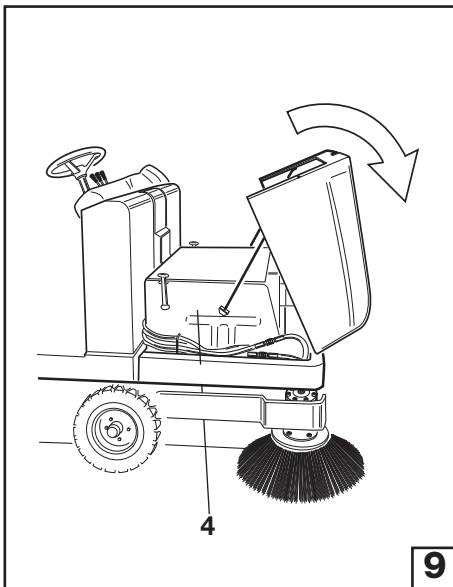

• **CONTENITORE DI RACCOLTA**

Il cassetto di raccolta in lamiera d'acciaio, part. 4 Fig. 9, serve a contenere tutto il materiale raccolto dalla spazzola centrale e la polvere del filtro.

**IMPORTANTE:** L'operazione di svuotamento del contenitore deve sempre essere eseguita munendosi di guanti ed eventualmente mascherina per proteggere le vie respiratorie dalla polvere, sempre presente in questa operazione.

• **SVUOTAMENTO DEL CONTENITORE DI RACCOLTA**

Per svuotare il contenitore di raccolta procedere come segue, part. 4 Fig. 9:

- 1.Scuotere il filtro per almeno 10" a flap e contenitore chiusi, verificare che il motore aspirazione non sia in funzione.
- 2.Sollevarre il contenitore al livello necessario.
- 3.Aprire il flap.

• **SISTEMA FILTRANTE**

Il sistema filtrante è costituito dal filtro in tessuto part. 41 Fig.10; esso permette alla macchina di poter spazzare senza sollevare polvere.

• **GUARNIZIONI ANTIPOLVERE**

Le guarnizioni antipolvere, part. A-B-C-D Fig. 11, sono importantissime per il buon funzionamento della macchina; esse circondano la spazzola centrale e permettono l'effetto aspirante. È importante perciò verificare spesso la loro buona condizione.

**ELENCO GUARNIZIONI**

- A. Guarnizione laterale dx.
- B. Guarnizione laterale sx (non visibile).
- C. Guarnizione posteriore.
- D. Guarnizione flap.

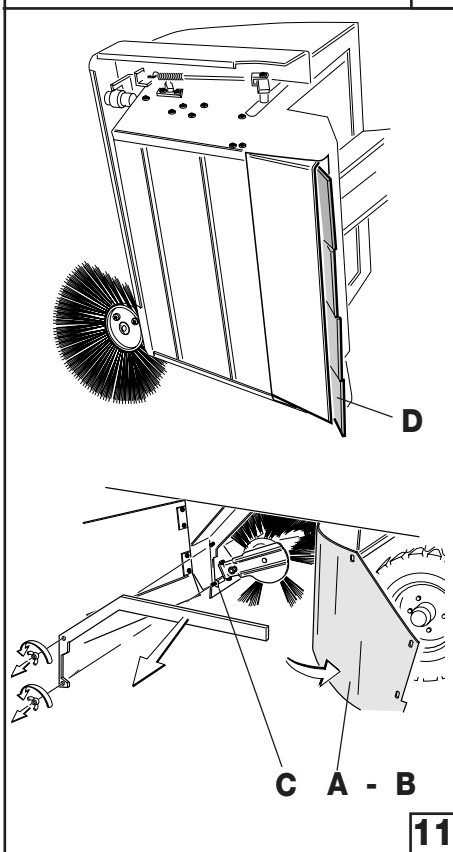
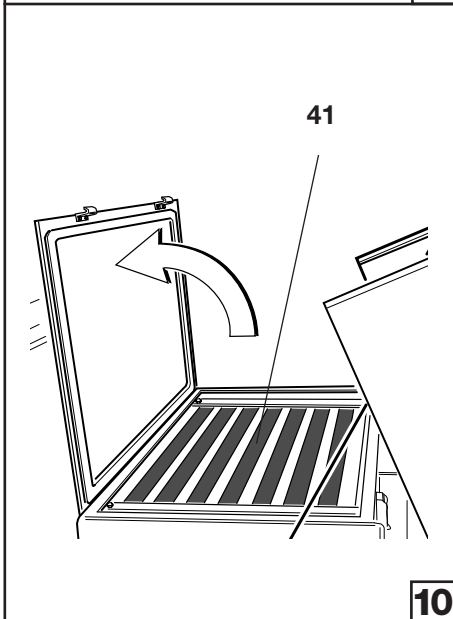

• **COLLECTION CONTAINER**

The collection box made of sheet steel, part 4 Fig. 9, contains all the material collected by the central brush and the dust from the filter .

**IMPORTANT:** Emptying the container must always be done with the wear gloves and possibly a mask to protect your mask to protect your mask to protect your lungs from the dust that lungs from the dust that lungs from the dust that is ever present in this job.

• **EMPTYING THE COLLECTING CONTAINER**

To empty the collecting container, proceed as follows, part 4 Fig. 9:

- 1.Keep shaking the filter for at least 10 " while keeping the flap and container closed, make sure that the suction motor is not working.
- 2.Lift the container at the necessary level.
- 3.Open the flap.

• **FILTERING SYSTEM**

The filtering system consists in a fabric filter part. 41 Fig.10; it allows the machine to brush without raising dust.

• **DUST FLAPS**

The dust flaps, part A-B-C-D Fig. 11, are very important for the correct functioning of the sweeper; they surround the central brush and help provide a suction effect. It is therefore important to check the good condition of these flaps frequently.

**LIST SEALS**

- A. RH seal.
- B. LH seal (not in sight).
- C. Rear seal.
- D. Flap seal.



## • CONTAINER DE RAMASSAGE

Le tiroir de ramassage en tôle d'acier, part. 4 Fig. 9, sert pour contenir tout le matériel ramassé par la brosse centrale et la poussière du filtre.

**IMPORTANT:** L'opération de vidange du conteneur doit toujours être exécutée en se servant de gant et set éventuellement d'une masque pour protéger les voies respiratoires de la poussière, toujours présente en cette opération.

## • VIDAGE DU CONTAINER DE RAMASSAGE

Pour vider le conteneur de ramassage, procéder comme suit, part. 4 Fig. 9:

**1.**Secouer le filtre pendant au moins 10 " avec le flap et le conteneur fermés, vérifier que le moteur d'aspiration ne soit pas en fonction.

**2.**Soulever le conteneur au niveau nécessaire.

**3.**Ouvrir le flap.

## • SYSTÈME DE FILTRAGE

Le système filtrant comprend un filtre en tissu part. 41 Fig.10; il permet à la machine de pouvoir balayer sans faire de la poussière.

## • JOINTS ANTI-POUSSIÈRE

Les joints anti-poussière, part. A-B-C-D Fig. 11, sont très importants pour le bon fonctionnement de la machine; ils circoncent la brosse centrale et permettent l'effet aspirant. Il est pourtant important qu'on vérifie souvent leur bon état.

## LISTE JOINTS

- A. Joint latéral droit.
- B. Joint latéral gauche (pas visible).
- C. Joint arrière.
- D. Joint flap.

## • SAMMELBEHÄLTER

Der Sammelbehälter aus Stahlblech, Teil 4 Abb. 9, dient als Behälter für das von der Hauptbürste gesammelte Material sowie auch den Filterstaub.

**WICHTIG :** Die Entleerung des Behälters muß immer mit ausgeschaltetem indem man eine Staubschutzmaske zur Schutzzung der Atemwege trägt. Bei dem ganzen Verfahren ist Staub immer anwesend.

## • ENTLERUNG DES SAMMELBEHÄLTERS

Um den Sammelbehälter zu entleeren, verfahren Sie wie folgt, Teil 4 Abb. 9:

**1.**Den Filter für mindestens 10 " mit geschlossenen Klappe und Behälter schütteln, beachten Sie dabei, daß der Absaugmotor nicht in Betrieb ist.

**2.**Den Behälter zur notwendigen Höhe aufheben.

**3.**Die Klappe aufmachen.

## • FILTERSYSTEM

Das Filtersystem besteht aus einem Gewebefilter Teil 41 Abb.10; es erlaubt der Maschine zu fegen, ohne Staub zu erheben.

## • STAUBSCHUTZDICHTUNGEN

Die Staubschutzdichtungen, Teil. A-B-C-D Fig.11, sind sehr wichtig für die einwandfreie Arbeitsweise der Maschine; sie umschließen die Hauptbürste und erlauben eine Absaugwirkung. Es ist deshalb wichtig, ihren guten Zustand oft zu prüfen.

Es ist sehr wichtig, daß die Dichtung vom Klappe-Behälter immer in gutem Zustand ist.

## LISTE DER DICHTUNGEN

- A. Rechte Seitendichtung
- B. Linke Seitendichtung (nicht sichtbar)
- C. Hintere Dichtung
- D. Flapdichtung

## • CONTENEDOR DE RECOGIDA

El cajón de recogida en chapa de acero, part. 4 Fig. 9, sirve para contener todo el material recolectado por el cepillo central y el polvo del filtro.

**IMPORTANTE:** La operación de vaciado del contenedor siempre tiene que ser ejecutada sirviéndose de guantes y eventualmente máscara para proteger las vías respiratorias contra el polvo, siempre presente en esta operación.

## • VACIADO DEL CONTENEDOR DE RECOGIDA

Para vaciar el contenedor de recogida hay que actuar como sigue, part. 4 Fig. 9:

**1.**Sacudir el filtro por al menos 10 segundos con flap y contenedor cerrados, comprobar que el motor de aspiración no esté en función.

**2.**Levantar el contenedor al nivel necesario.

**3.**Abrir el flap.

## • SISTEMA FILTRANTE

El sistema filtrante comprende el filtro de tejido part. 41 Fig.10; esto permite a la máquina de poder barrer sin levantar polvo.

## • EMPAQUETADURAS ANTIPOLVO

(VÁLIDO PARA TODOS LOS MODELOS)

Las empaquetaduras antipolvo, part. A-B-C-D Fig. 11, son muy importantes para el buen funcionamiento de la máquina; ellas rodean el cepillo central y permiten el efecto aspirante. Es entonces importante que se compruebe a menudo su buen estado.

## LISTA EMPAQUETADURAS

- A. Empaquetadura lateral derecha.
- B. Empaquetadura lateral izq.(no visible).
- C. Empaquetadura trasera.
- D. Empaquetadura flap.

• DESCRIZIONE DEI COMANDI

• DESCRIPTION OF CONTROLS

**INTERR. AVVIAMENTO part 19 Fig 12**

- Posizione OFF
- 1° scatto  preriscaldamento candele
- 2° scatto  accensione

**STARTING SWITCH part 19 Fig 12**

- Position OFF
- 1st step  preheating of glow plugs
- 2nd step  ignition

**COMANDI IDRAULICI part 18 Fig 12**

- 1) Leva destra con ritorno a zero
  - posizione A apre il flap
  - posizione B chiude il flap
- 2) Leva centrale con ritorno a zero solo in posizione B
  - posizione A le spazzole centrale e laterale si abbassano e girano.
  - posizione B le spazzole centrale e laterale si sollevano e si fermano.
- 3) Leva sinistra con ritorno a zero
  - posizione A alza il contenitore
  - posizione B abbassa il contenitore

**HYDRAULIC CONTROLS part 18 Fig 12**

- 1) RH lever with return to zero
  - position A opens the flap
  - position B closes the flap
- 2) Central lever with return to zero only in position B
  - position A the central and lateral brushes fall and rotate.
  - position B the central and lateral brushes raise and stop.
- 3) LH lever with return to zero
  - position A raises the container
  - position B lowers the container

**Fig. 12 part.26 :** quando la levetta del deviatore è in pos.A la spazzola lat. è in funzione, quando è in pos.B la spazzola lat. è ferma.

**Fig. 12 part 26 :** when the switch lever is in pos. A, the lateral brush is operating, when it is in pos. B the lateral brush is idle.

**MOSTRINA INTERRUITORI**

- A Interruttore clacson
- B Interruttore motore ventola aspirazione e interruttore motore squotifiltro
- C Interruttore fanali

**SWITCHES BADGE**

- A Klaxon switch
- B Suction fan motor switch and shaking motor switch
- C Switch lights

**LEVA ACCELERATORE part 17 Fig 12**

In fase di lavoro la leva deve essere in posizione A (a fine corsa)

**ACCELERATOR LEVER part 17 Fig 12**

During work, the lever must be in position A (at stroke end)

**STRUMENTO MULTIFUNZIONE**

- part 21 Fig 12**
- Contaore
  - Indicatore livello carburante
  - Spie

**MULTIFUNCTION TOOL**

- part 21 Fig 12**
- Hours counter
  - Fuel level indicator
  - Indicator lights

**PORTAFUSIBILI part 24 Fig 12**

Vedi esplosi ricambi

**FUSE HOLDER part 24 Fig 12**

See exploded views spare parts

**AVANZAMENTO part 12 Fig 12**

Il pedale pos. 12 è del tipo basculante pertanto premendo lo stesso in avanti la macchina avanza da 0 alla max velocità, mentre premendo la parte posteriore la macchina arretra.

**MARCH FORWARD part 12 Fig 12**

The pedal pos. 12 is horizontally pivoted therefore by pressing the same forward the machine goes from max speed, while by pressing the rear part, the machine goes backward.

**PEDALE FRENO DI SERVIZIO**

**part 13 Fig 12**  
Il pedale freno pos. 13 agisce meccanicamente sui due mozzi delle ruote anteriori.

**WORK BRAKE PEDAL part 13 Fig.12**

The brake pedal position 13 acts mechanically on the two hubs of the front wheels.

**FRENO DI STAZIONAMENTO**

**part 14 Fig 12**  
Il freno di stazionamento, come il pedale, agisce sui 2 mozzi delle ruote anteriori.

**PARKING BRAKE LEVER part 14 Fig.12**

The parking brake lever, same as the pedal, acts on the two hubs of the front wheels

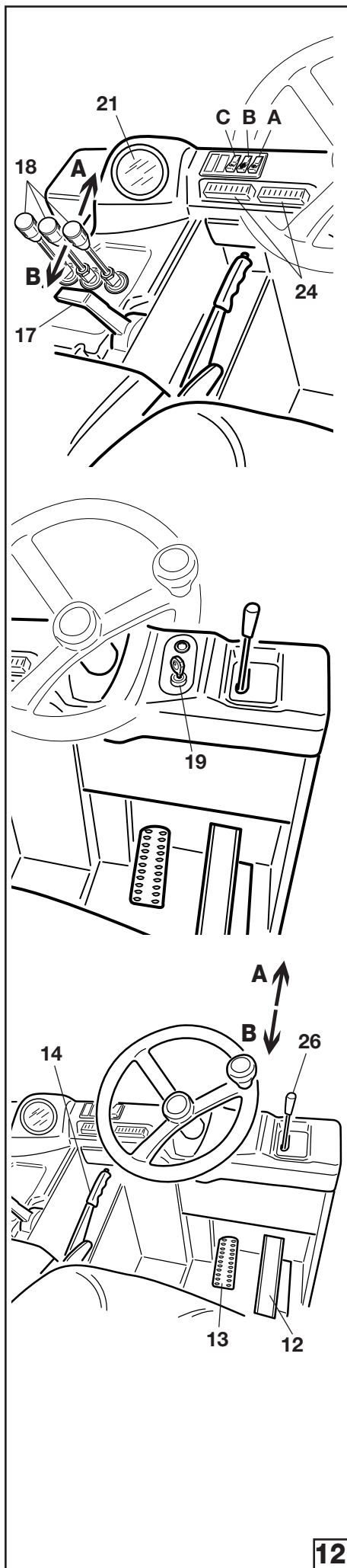

## • DESCRIPTION DES COMMANDES

### INTERRUPTEUR DÉMARRAGE part 19

-Position OFF

-1er dé clic pré-chauffage bougies

-2ème dé clic allumage

### COMMANDES HYDRAULIQUES part 18

1) Levier droit avec retour à zéro

-position A ouvre le flap

-position B ferme le flap

2) Levier centrale avec retour à zéro seulement en position B

-position A les brosses centrale et latérale se baissent et tournent.

-position B les brosses centrale et latérale se soulèvent et s'arrêtent.

3) Levier gauche avec retour à zéro

-position A hausse le conteneur

-position B baisse le conteneur

**Fig. 12 pièce 26** : lorsque le levier du déviateur est en pos. A la brosse lat. est en marche, lorsqu'il est en pos. B la brosse lat. est arrêtée.

### PANNEAU INTERRUPTEURS

**A** Interrupteur klaxon

**B** Interr. ventilateur aspiration et interr. moteur secoueur de filtre

**C** Interrupteur feux

### LEVIER ACCÉLÉRATEUR part 17 Fig 12

En phase de travail, le levier doit être en position A (en fin de course)

### OUTILS MULTIFONCTIONS

part. 21 Fig. 12

- Compteur d'heures

- Jauge de carburant

- Lumières

### PORTE-FUSIBLES pièce 24 Fig 12

Voir des vues éclatées de pièces de rechange

### AVANCEMENT pièce 12 Fig 12

La pédale pos. 12 è de type basculant pourtant en appuyant sur le même en avant, la machine avance de 0 à la vitesse maxi, tandis qu'en appuyant sur la partie arrière la machine recule.

### FREIN DE SERVICE pièce 13 Fig 12

La pédale du frein position 13 agit mécaniquement sur les deux moyeux des roues antérieures .

### FREIN DE STATIONNEMENT

pièce 14 Fig 12:

Le frein de stationnement, ainsi comme la pédale, agit sur les deux moyeux des roues antérieures.

## • BESCHREIBUNG DER STEUERUNGEN

### STARTER Teil 19 Abb. 12

-Position OFF

-1. Klick Vorglühen

-2. Klick Zündung

### HYDRAULISCHE STEUERUNGEN part 18

1) Rechter Hebel mit Null-Rückkehr

-Position A öffnet die Klappe

-Position B schließt die Klappe

2) Zentraler Hebel mit Null-Rückkehr nur auf Position B

-Position A die zentr. und seitl. Bürsten sinken und drehen.

-Position B die zentrale und seitliche Bürsten sich aufheben und stoppen.

3) Linker Hebel mit Null-Rückkehr

-Position A hebt den Behälter

-Position B senkt den Behälter

**Abb.12 Teil 26** : wenn der Hebel des Wechselschalter auf Pos. A ist, ist die Seitenbürste in Betrieb, wenn er auf Pos. B ist, liegt die Seitenbürste still.

### SCHALTER

**A** Autohupeschalter

**B** Schalter des Absaugmotors und Schalter des Filterschüttlers

**C** Lichtschalter

### GASHEBEL Teil 17 Abb. 12

Wenn die Maschine in Betrieb ist, muß der Hebel auf Position A (am Endanschlag) sein.

### MULTIFUNKTIONSWERKZEUG

teil 21 Abb 12

- Stundenzähler

- Kraftstoffanzeige

- LED-Leuchten

### SICHERUNGSTRÄGER Teil 24 Abb. 12

Siehe Explosionszeichnungen Ersatzteile

### VORSCHUB Pos.12 Abb. 12

Das Pedal Pos. 12 ist schwingend: das heißt, wenn man es nach vorne drückt, fährt die Maschine vorwärts von 0 bis zur höchste Geschwindigkeit, wenn man es nach hinter drückt, fährt die Maschine rückwärts .

### BREMSPEDAL Position 13 Abb. 12

Das Bremspedal Position 13 wirkt mechanisch auf die zwei Naben der Vorderräder.

### HANDBREMSE Position 14 Abb. 12

Die Handbremse, wie das Bremspedal, wirkt auf die zwei Naben der Vorderräder.

## • DESCRIPCIÓN DE LOS MANDOS

### INTERR. DE MARCHA part 18 Fig 12

-Posición OFF

-1° piñón precalentamiento bujías

-2° piñón encendido

### MANDOS HIDRAULICOS part 18 Fig 12

1) Leva derecha con retorno a cero

-posición A abre el flap

-posición B cierra el flap

2) Leva central con retorno a cero sólo en posición B

-posición A los cepillos central y lateral bajan y giran.

-posición B los cepillos central y lateral suben y se paran.

3) Leva izquierda con retorno a cero

-posición A levanta el contenedor

-posición B baja el contenedor

**Fig. 12 part. 26** : cuando la leva del desviador está en pos.A, el cepillo lat. está en función, cuando está en pos. B el cepillo lat. está parado.

### PANEL INTERRUPTORES

**A** interruptor klaxon

**B** interruptor motor ventilador aspiración y interruptor motor sacudidor

**C** interruptor luces

### LEVA ACCELERADOR part 17 Fig 12

En fase de trabajo la leva debe estar en posición A (a final de carrera)

### HERRAMIENTA MULTIFUNCION

part 21 Fig 12

- Cuentahoras

- Indicador de combustible

- Luces

### PORTAFUSIBLES part. 24 Fig 12

Ver las vistas ampliadas recambios

### AVANCE part. 12 Fig 12

El pedale pos. 12 es de tipo basculante por lo tanto apretando el mismo hacia adelante, la máquina avanza de 0 a la máxima velocidad, mientras que apretando la parte trasera, la máquina arredra.

### FRENO DE SERVICIO part. 13 Fig 12

El pedale freno posición 13 actua mecánicamente en los dos cubos de las ruedas delanteras.

### FRENO DE ESTACIONAMIENTO

part. 14 Fig 12:

El freno de estacionamiento, así como el pedal, actua en los dos cubos de las ruedas delanteras.

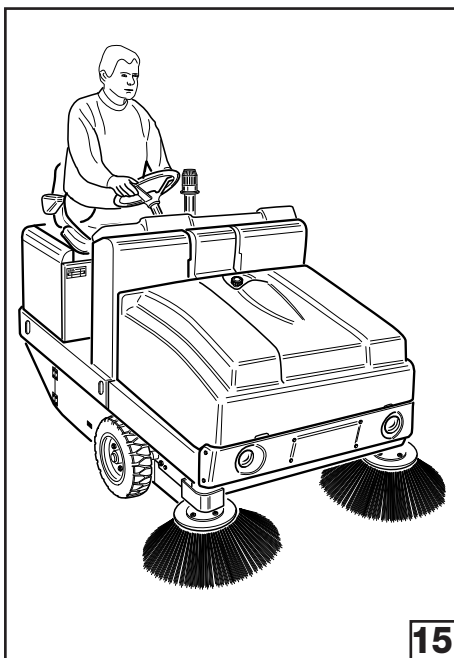

15

**7. POSTO DI LAVORO OCCUPATO DALL' OPERATORE/ ARRESTO DI EMERGENZA/ SICUREZZA CONTENITORE SOLLEVATO**

**• POSTO DI LAVORO**

Il posto di lavoro che deve essere occupato dall'operatore durante l'uso della macchina è solamente quello riportato in Fig. 15.

**• ARRESTO DI EMERGENZA**

Lasciare il pedale di comando avanzamento part. 12 Fig.12, frenare la macchina premendo il pedale del freno di servizio part.13 Fig.12, girare in senso antiorario la chiave avviamento part. 19 Fig.12.

In caso di mancato funzionamento del freno di servizio, tirare a fondo la leva freno di stazionamento part.14 Fig.12.

**• SICUREZZA CONTENITORE SOLLEVATO**

Inserire l'asta di sicurezza nell'apposita sede.Fig.16

**7. OPERATOR WORKING POSITION / EMERGENCY STOP/ SAFETY FROM RAISED CONTAINER**

**• WORKING POSITION**

When using the sweeper, the operator must be in the working position shown in Fig 15.

**• EMERGENCY STOP**

Release the start pedal part. 12 Fig. 12, stop the machine by pressing the work brake pedal part 13 Fig. 12, turn the ignition key counterclockwise part 19 Fig. 12 .In case of malfunctioning of the work brake, pull the lever parking brake work brake fully part 14 Fig. 12.

**•SAFETY FROM RAISED CONTAINER**

Insert the safety rod in its housing.Fig.16

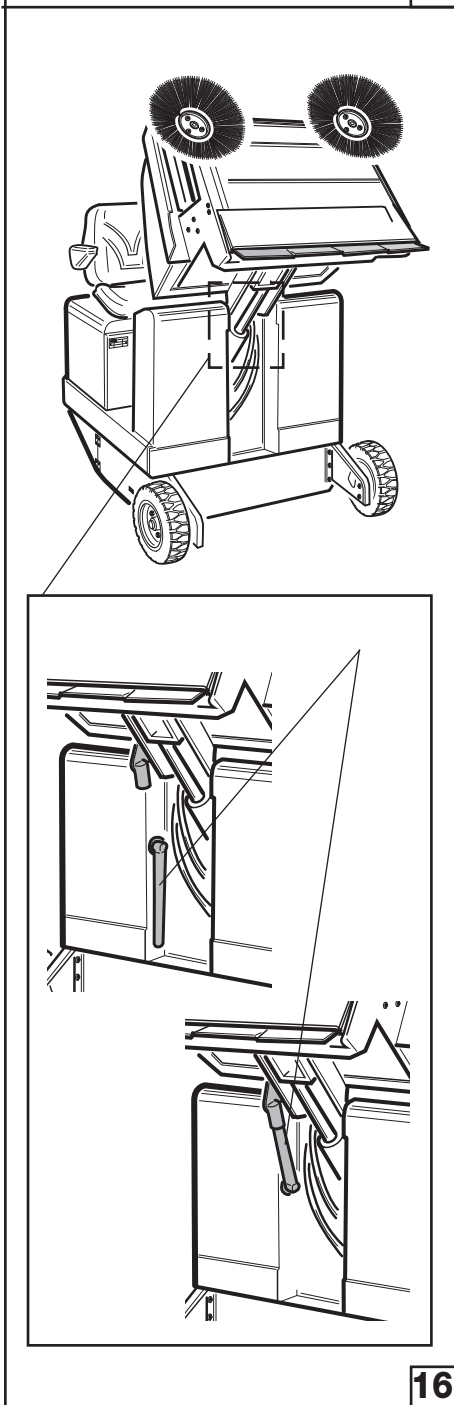

16

## **7. POSTE DE TRAVAIL OCCUPÉ PAR L'OPÉRATEUR / ARRÊT D'URGENCE /SECURITE CONTENEUR SOULEVE**

### **• POSTE DE TRAVAIL**

Le poste de travail qui doit être occupé par l'opérateur pendant l'emploi de la machine est seulement celui indiqué en Fig. 15.

### **• ARRÊT D'URGENCE**

Relâcher la pédale de commande avancement part. 12 Fig. 12, freiner la machine en appuyant sur la pédale du frein de service part. 13 Fig.12, tourner de droite à gauche la clé de démarrage part. 19 Fig. 12. En cas de non fonctionnement du frein de service, tirer à fond le levier de frein de stationnement part. 14 Fig. 12.

### **• SÉCURITÉ CONTENEUR SOULEVÉ**

Introduire la tige de sécurité dans son logement.Fig.16

## **7. ARBEITSPLATZ VOM OPE- RATOR BESETZT/ NOTBREMSE/ SICHERHEIT BEHÄLTER AUFGEHOBEN**

### **• ARBEITSPLATZ**

Der Arbeitsplatz, den der Operator beim Gebrauch der Maschine besetzen muß, ist nur wie auf Abb. 15 angezeigt.

### **• NOTBREMSE**

Das Fahrpedal Teil 12 Abb. 12 loslassen, die Maschine mit der Arbeitsbremse Teil 13 Abb. 12 bremsen, den Zündschlüssel Teil 19 Abb.12 im Gegenuhrzeigersinn drehen. Sollte die Arbeitsbremse, dann ziehen Sie die Handbremse Teil 14 Abb. 12 voll.

### **• SICHERHEIT BEHÄLTER AUFGEHOBEN**

Die Sicherheitsstange in ihren Sitz eingeben. Abb.16

## **7. PUESTO DE TRABAJO OCUPADO POR EL OPERADOR / PARADA DE EMERGENCIA**

### **• PUESTO DE TRABAJO**

El puesto de trabajo que tiene que ser ocupado por el operador durante el uso de la máquina es solamente aquello detallado en Fig. 15.

### **• PARADA DE EMERGENCIA**

Deje el pedal de mando avance part. 12 Fig. 12, frene la máquina apretando el pedal del freno de servicio part. 13 Fig.12, gire en sentido antihorario la llave de puesta en marcha part. 19 Fig.12.

En caso de falta de funcionamiento del freno de servicio, tire a fondo la leva del freno de estacionamiento part. 14 Fig.12.

### **•SECURIDAD CONTENEDOR LEVANTADO**

Introduzca el asta de seguridad en su sede. Fig.16

## 8. NORME DI SICUREZZA

### RISCHI RESIDUI NON ELIMINABILI VALIDI PER TUTTI I MODELLI

**DEFINIZIONE:** I rischi residui non eliminabili, sono tutti quelli che per diverse ragioni, non possono essere tolti, ma che per ognuno dei quali riportiamo le indicazioni per operare nell'ambito della sicurezza.

I rischi specifici per macchine a scoppio e a batteria sono riportati in successione, in sezione distinte, 1 e 2.

1) Rischio di lesioni alle mani al corpo e alla vista, usando la macchina senza tutte le protezioni di sicurezza correttamente montate ed integre.

2) Rischio di lesioni alle mani volendo toccare per qualsiasi ragione la spazzola laterale o la spazzola centrale durante la rotazione, le spazzole possono essere toccate solo a motore spento e con l'ausilio di guanti di protezione, per evitare di pungersi o tagliarsi se eventualmente nelle setole fossero presenti schegge appuntite di detriti in genere.

3) Rischio di inalazione di sostanze nocive, abrasioni alle mani, effettuando lo svuotamento del contenitore (cassetto), senza utilizzare guanti di protezione e mascherina per proteggere le vie respiratorie.

**SEZIONE 1: RISCHI RESIDUI PER MACCHINE FUNZIONANTI A MOTORE A SCOPPIO, CONSULTARE ANCHE IL LIBRETTO DEL MOTORE ALLEGATO, AL CAP. NORME DI SICUREZZA.**

1) Rischio di scoppio o incendio effettuando rifornimento a motore acceso o a motore spento non completamente freddo.

2) Rischio di gravi ustioni, eseguendo qualsiasi manutenzione a motore spento non completamente freddo.

## 8. SAFETY RULES AND REGULATIONS

### RESIDUAL RISKS THAT CANNOT BE ELIMINATED AND VALID FOR ALL MODELS

**DEFINITION:** Unavoidable residual risks are all those risks that, for various reasons, cannot be eliminated, and for each of which instructions for safe operation are given below. The specific risks relating to internal combustion engine and battery-powered machines are given in sequence and in separate sections, 1 and 2.

1) Risk of injury to the hands, body and eyes using the machine without all the safety guards correctly mounted or if they are damaged.

2) Risk of injury to the hands by touching the side brush or central brush for any reason while they are rotating; the brushes may be touched only when the motor is off and you are wearing protective gloves in order to avoid being cut or pricked by sharp pieces of dirt in the bristles.

3) Risk of inhaling harmful substances, of scratching your hands when emptying the container (box) without using protective gloves and face mask to protect your lungs.

**SECTION 1: RESIDUAL RISKS FOR SWEEPERS POWERED BY INTERNAL COMBUSTION ENGINES, ALSO REFER TO THE ENCLOSED ENGINE BOOKLET, SAFETY RULES AND REGULATIONS CHAPTER.**

1) Explosion or fire hazard if refuelling while the engine is on or if it is off but not completely cold.

2) Serious burns hazard if you are servicing the sweeper when the engine is off but not completely cold.

## 8. NORMES DE SÉCURITÉ

### RISQUES RÉSIDUELS NON ÉLIMINABLES VALABLES POUR TOUS LES MODÈLES

**DÉFINITION:** Les risques résiduels non éliminables, sont tous ceux qui pour plusieurs raisons, ne peuvent pas être enlevés. Pour chacun de ces risques, on indique ci-après les instructions pour opérer dans la sécurité.

Les risques spécifiques pour les machines à explosion et à batterie sont mentionnés en succession, dans les sections 1 et 2.

1) Risque de lésions aux mains, au corps et aux yeux, si on utilise la machine sans toutes les protections de sécurité correctement montées et intactes.

2) Risque de lésions aux mains si l'on veut toucher pour n'importe-quelle raison la brosse latérale ou la brosse centrale pendant la rotation, les brosses peuvent être touchées seulement à moteur éteint et à l'aide de gants de protection, pour éviter de se piquer ou couper si éventuellement parmi les soies se trouvent des éclats pointus de déchets en général.

3) Risque d'inhalation de substances nuisibles, abrasions aux mains, en effectuant le vidange du conteneur (tiroir), sans utiliser les gants de protection et la masque pour protéger les voies respiratoires.

#### SECTION 1: RISQUES RÉSIDUELS POUR MACHINES AVEC MOTEUR À EXPLOSION,CONSULTER ÉGALEMENT LE MANUEL DU MOTEUR CI-JOINT, AU CHAP. NORMES DE SÉCURITÉ.

1) Risque d'explosion ou incendie en effectuant ravitaillement à moteur éteint ou à moteur éteint non entièrement froid.

2) Risque de graves brûlures, en effectuant n'importe-quelle entretien à moteur éteint non entièrement froid.

## 8. SICHERHEITSNORMEN

### RESTLICHE RISIKEN, DIE NICHT BESEITIGT WERDEN KÖNNEN UND FÜR ALLE MODELLE GÜLTIG SIND.

**BESTIMMUNG:** Die nicht-entfernbar restlichen Risiken sind jene die, aus verschiedenen Gründen, nicht beseitigt werden können. Für jedes Risiko geben wir Angaben an, um in Sicherheit arbeiten zu können.Die bestimmten Risiken für die Diesel- sowie auch für die batteriebetriebenen Maschinen sind in Folge beschrieben worden, auf verschiedenen Abschnitten, 1 und 2.

1) Risiko einer Verletzung der Hände, Körper und Augen, beim Gebrauch der Maschine ohne alle korrekt eingebauten und vollständigen Schutzvorrichtungen.

2) Risiko einer Verletzung der Hände, beim Berühren der rotierenden Seitenbürste oder Hauptbürste. Man kann die Bürsten berühren, nur mit ausgeschalteten Motor und mit Schutzhandschuhen, um zu vermeiden, sich zu stechen oder schneiden, im Falle von Spitzsplintern zwischen den Borsten.

3) Risiko der Inhalation von Schadstoffen, der Abschürfung der Hände, bei der Entleerung des Behälters (Schublade), ohne Schutzhandschuhen und Schutzmaske für die Atemwege.

#### ABSCHNITT 1: RESTLICHE RISIKEN FÜR DIESEL-BETRIEBENE MASCHINEN. SCHLAGEN SIE AUCH BITTE IN DER BEIGEFÜGTEN BETRIEB-SANLEITUNG DES MOTORS, IM KAP. SICHERHEITSNORMEN NACH.

1) Risiko einer Explosion oder eines Brandes beim Tanken mit laufendem Motor oder mit stillstehendem aber nicht völlig kaltem Motor.

2) Risiko, sich schwer zu verbrennen, beim Durchführen von Wartungen mit stillstehendem aber nicht völlig kaltem Motor.

## 8. NORMAS DE SEGURIDAD

### RIESGOS RESTANTES NO ELIMINABLES VÁLIDOS PARA TODOS LOS MODELOS

**DEFINICIÓN:** Los riesgos restantes no eliminables, son todos aquellos que por varias razones, no pueden ser quitados, pero que para cadauno de ellos detallamos las indicaciones para poder operar en toda seguridad.

Los riesgos específicos para máquinas de explosión y a batería están detallados en seguida, en secciones distinguidas, 1 y 2.

1) Riesgo de lesiones a las manos al cuerpo y a los ojos, usando la máquina sin todas las protecciones de seguridad correctamente montadas y íntegras.

2) Riesgo de lesiones a las manos si se quiere tocar por cualquier razón el cepillo lateral o el cepillo central durante la rotación, los cepillos pueden ser tocados solo con motor apagado y con la ayuda de guantes de protección, para evitar de picarse o cortarse se por acaso en las cuerdas se encuentran astillas pontiagudas de desechos en general.

3) Riesgo de inhalación de sustancias nocivas, abrasiones a las manos, efectuando el vaciado del contenedor (cajón), sin utilizar guantes de protección y máscara para proteger las vías respiratorias.

#### SECCIÓN 1: RIESGOS RESTANTES PARA MÁQUINAS CON MOTOR DE EXPLOSIÓN, CONSULTE TAMBIÉN EL MANUAL DEL MOTOR ADJUNTO, AL CÁP. NORMAS DE SEGURIDAD.

1) Riesgo de explosión o incendio efectuando el abastecimiento con motor en marcha o con motor apagado pero no completamente frío.

2) Riesgo de graves ustiones, efectuando cualquier manutención con motor apagado pero no completamente frío.



## 9. CONTROLLI PRIMA DELL'AVVIAMENTO

**IMPORTANTE:** Il sedile, part.6 Fig.17, è dotato di un interruttore di sicurezza che spegne il motore nel caso in cui l'operatore non sia correttamente seduto. Pertanto per consentire il funzionamento della macchina è indispensabile che l'operatore occupi correttamente il posto di lavoro come anche richiamato al capitolo 7.

### MODELLO 160 DK FUNZIONANTE CON MOTORE ENDOTERMICO

Leggere attentamente il libretto di istruzioni del motore, che troverete allegato al qui presente libretto della macchina, ma comunque:

controllare il livello olio del motore, se è basso, rabboccate indossando guanti di protezione possibilmente di nitrile (interno cotone);

L'olio da noi consigliato per climi temperati è 15W-40. Fare rifornimento di gasolio (motore spento e freddo).

**ATTENZIONE :** TENETE IL GASOLIO FUORI DALLA PORTATA DEI BAMBINI, IN UN LUOGO ASCIUTTO E AERATO, LONTANO DA FONTI DI CALORE.



**IMPORTANTE :** Il contenitore del gasolio deve essere adatto a tale scopo e ben pulito, ciò vi assicurerà una buona durata del filtro nafta del motore.

## 9. CHECKS PRIOR TO START-UP

**IMPORTANT :** The seat, part 6 Fig. 17, is fitted with a safety switch which switches off the motor should not the operator be correctly seated. Therefore, to allow the machine to work properly, it is imperative for the operator to occupy the work site correctly as indicated at chapter 7.

### MODEL 160 DK OPERATING WITH ENDOTHERMAL MOTOR

Read carefully the operating manual of the motor which is attached to this machine operating manual, however:

Check the oil level inside the motor, if it is low, fill up by wearing safety gloves possibly in nitrile (with cotton inside).

The oil that we suggest for temperate climates is 15W-40.

Refuel with gasoil (motor must be off and cold).

**CAUTION :** KEEP GASOIL AWAY FROM CHILDREN, IN A DRY AND VENTILATED PLACE, AWAY FROM HEAT SOURCES.



**IMPORTANT :** The gasoil container must be suitable to this purpose and perfectly clean, this will assure a long life to the motor gasoil filter.



## 9. CONTRÔLES AVANT LE DÉMARRAGE

**IMPORTANT :** Le siège, part. 6 Fig. 17 est pourvu d'un interrupteur de sécurité qui arrête le moteur si l'opérateur n'est pas correctement assis. Pourtant, pour permettre le fonctionnement de la machine, il faut que l'opérateur occupe correctement la place de travail comme indiqué au chapitre 7.

### MODÈLE 160 DK AVEC MOTEUR ENDOTHERMIQUE

Lire attentivement le manuel d'emploi du moteur, qui est joint à ce manuel de la machine, c'est-à-dire:

vérifier le niveau de l'huile du moteur, s'il est bas, en ajouter en portant des gants de protection possiblement en nitrile (intérieur en coton).

L'huile recommandé pour les climats tempérés est 15W-40.

Faire le plein de gasoil (moteur arrêté et froid).

**ATTENTION :** GARDER LE GASOIL LOIN DE LA PORTÉE DES ENFANTS, DANS UNE PLACE SÈCHE ET AERÉE, LOIN DE SOURCES DE CHALEUR.



**IMPORTANT :** Le conteneur du gasoil doit être adapté pour ça et très propre, cela vous assurera une longue buona durée du filtre gasoil du moteur .

## 9. ÜBERPRÜFUNGEN VOR DEM EINSCHALTEN

**WICHTIG :** Der Sitz, Teil 6 Abb. 17, ist mit einem Sicherheitsschalter ausgerüstet, der den Motor ausschaltet, wenn der Operator nicht korrekt gesessen ist. Deshalb, um eine einwandfreie Arbeitsweise der Maschine zu erlauben, muß der Operator unbedingt korrekt gesessen sein, siehe auch den Kapitel 7.

### MODELL 160 DK MIT DIESEL-MOTOR

Lesen Sie sorgfältig die Betriebsanleitung des Motors durch, die Sie dieser Betriebsanleitung der Maschine beigelegt finden, aber auch: Prüfen Sie den Ölstand des Motors, wenn er zu tief ist, dann füllen Sie auf, indem Sie Schutzhandschuhe, möglicherweise aus Nitril (mit Baumwolle drin) tragen.

Das von uns für kalte Klimate empfohlene Öl lautet: 15W-40. Mit Gasöl tanken (mit ausgeschalteten und kaltem Motor).

**VORSICHT :** GASÖL MUSS UNERREICHBAR FÜR KINDER, IN EINEM TROCKENEN, GELÜFTETEN UND FERN VON HITZE GELAGERT WERDEN.



**WICHTIG :** Der Kraftstoffbehälter muss dazu geeignet und sauber sein: dies wird dem Gasölfilter am Motor eine lange Lebensdauer versichern.

## 9. CONTROLES ANTES DE LA PUESTA EN MARCHA

**IMPORTANTE :** El asiento, part. 6 Fig. 17, está equipado con un interruptor de seguridad que apaga el motor en el caso en que el operados no esté correctamente sentado. Por lo tanto para permitir el funcionamiento de la máquina es indispensable que el operador ocupe correctamente el puesto de trabajo como también explicado al cap. 7

### MODELO 160 DK FUNCIONANTE CON MOTOR ENDOTERMICO

Lea atentamente el manual de empleo del motor, que está adjunto al manual de la máquina, pero de todas maneras:

Compruebe el nivel del aceite del motor, si está bajo, llene utilizando los guantes de protección posiblemente de nitril (interior de algodón).

El aceite aconsejado para los climas temperados es 15W-40.

Llene el depósito de gasoleo (con motor parado y frío).

**ATENCIÓN :** TENGA EL GASOLEO FUERA DEL ALCANCE DE LOS NIÑOS, EN UN LUGAR SECO Y AERADO, LEJOS DE FUENTES DE CALOR.



**IMPORTANT :** El contenedor del gasoleo debe ser apto para este fin y bien limpio, ésto asegurará una buena duración del filtro gasoleo del motor.

## 10. USO CORRETTO E CONSIGLI

**IMPORTANTE:** Prima di iniziare il lavoro, controllare se sulla superficie, sono presenti corde, fili di corrente ecc; questi sono pericolosi e potrebbero danneggiare le guarnizioni antipolvere. Occorre quindi eliminarli prima di iniziare il lavoro con la macchina.

Fare molta attenzione quando si passa sopra a rotaie, guide di portoni ecc. questi sono la fonte di maggior danno per le guarnizioni antipolvere. Evitate di passare sopra a pozzanghere, trovandosi in presenza di superfici umide alzare le spazzole. Se la superficie da pulire è molto sporca per quantità o qualità del materiale o polvere da raccogliere, si consiglia di effettuare una prima passata "di sgrossatura" senza curarsi troppo dell'aspetto ottenuto, quindi con il cassetto pulito ed il filtro ben vibrato, ripetere i passaggi; si otterrà così l'effetto desiderato. In seguito usando meto-dicamente ed opportunamente la macchina non si avrà più bisogno di effettuare "la sgrossatura". La spazzola laterale deve essere utilizzata solo per la pulizia di bordi, profili, angoli ecc., deve essere alzata (disinserita) subito dopo, per non sollevare inutile polvere, e perchè l'effetto pulito della spazzola laterale è sempre inferiore all'effetto pulito della spazzola centrale.

Per un buon risultato vuotate spesso il contenitore e tenete pulito i filtro vibrandolo con gli appositi strumenti.

## 10. CORRECT USE AND ADVICE

**IMPORTANT:** Before starting the operation, make sure that the surface is free from strings, wires, etc. since these are dangerous and could damage anti-dust seals. It is then necessary to remove these elements before using the machine.

Be very careful when crossing rails, door guides, etc. because these are the main cause of damage for anti-dust seals.

Also avoid passing on puddles: in presence of wet surfaces, raise the brushes.

If the surface to be cleaned is very dirty, due to the quantity or quality of the material or dust to be collected, we suggest to make a first "rough" sweeping without concentrating on the result, then with a clean drawer and well-vibrated filters, repeat the passages; this will allow you to reach the desired result.

Later on, after using the machine methodically and opportunely, there will be no need of making a first "rough" sweeping. The lateral brush must be used only for cleaning edges, profiles, corners, etc. It must be raised soon afterwards, to avoid raising dust in vain and also because the cleaning power of the lateral brush is always lower than the cleaning power of the central brush.

To get good results, empty the container often and keep clean the filter by shaking it with the relevant tools.

Livello olio  
Oil level  
Niveau huile  
Ölstand  
Nivel aceite

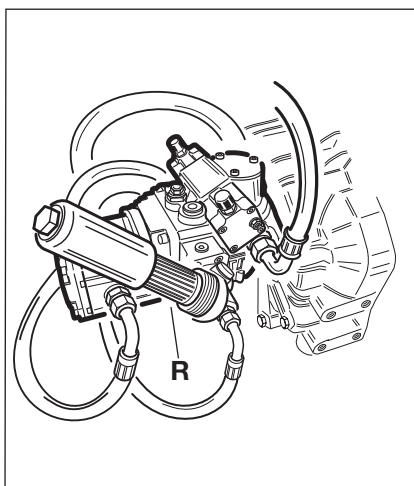
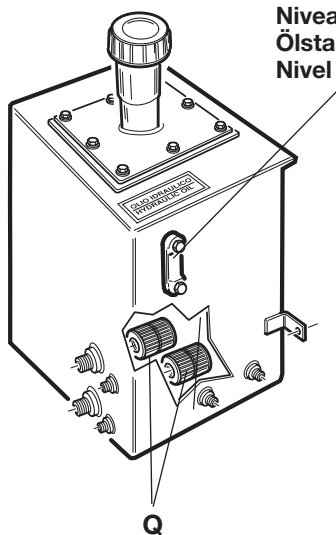

ESSO INVAROL	EP 46
AGIP ARNICA	46
MOBIL DTE OIL	15
BP ENERGOL SHF	46
IP HIDRUS OIL HI	46
FINA HYDRAN HV	46
SHELL TELLUS OIL ST	46

## 11. INTERVENTI DI MANUTENZIONE ORDINARIA

Tenere sotto controllo il livello olio idraulico, per evitare surriscaldamenti è necessario che sia sempre a livello.

Per eventuali rabbocchi utilizzare il seguente tipo di olio: vedi tabella Fig.18.

Per quanto riguarda i due filtri olio, la loro sostituzione è prevista: per il filtro **R** fig.18 dopo le prime 50 ore, in seguito ogni 500 ore, mentre per quanto riguarda il filtro **Q** fig.18 la sua sostituzione è prevista ogni 1000 ore, il sopraccitato filtro si trova all'interno del serbatoio pertanto è necessario togliere il coperchio allentando le otto viti con la chiave di 10, quindi svitare il filtro e sostituirlo.

## 11. ROUTINE MAINTENANCE

Keep the hydraulic oil level under control to avoid any overheating: it is necessary that it is always at level. In case of refilling, use the the following oil type: see table below Fig.18.

As to the two oil filters, their replacement is scheduled as follows: for the filter ref. **R** fig.18 after the first 50 working hours, then every 500 hours, whereas for the filter ref. **Q** fig.18 its replacement is foreseen every 1000 hours. The above filter is located inside the tank, therefore it is necessary to remove the lid by loosening the eight screws by means of the 10mm wrench, then loosen the filter and replace it.

## 10. UTILISATION CORRECTE ET CONSEILS

**IMPORTANT:** Avant de commencer le travail, vérifiez si sur la surface à balayer, il y a des cordes, des fils électriques, etc; ceux-ci sont dangereux et pourraient endommager les joints anti-poussière. Il faut donc les éliminer avant de commencer le travail avec la machine.

Faire beaucoup d'attention lorsqu'on passe sur des rails, ou guides de portes, etc. Ceux-ci sont la cause plus fréquente de dégât pour les joints anti-poussière.

Éviter de passer sur des flaques: à proximité de surfaces humides, soulever les brosses. Si la surface à nettoyer est très sale à cause de la quantité ou qualité du matériel ou poussière à ramasser, on conseille d'effectuer un premier passage "de dégrossissage" sans prêter trop d'attention à l'aspect obtenu, puis, avec le tiroir propre et les filtres bien vibrés, répéter les passages; on obtiendra ainsi l'effet désiré.

Ensuite, en utilisant méthodiquement et opportunément la machine il ne sera plus nécessaire d'effectuer "le dégrossissage". La brosse latérale doit être utilisée seulement pour le nettoyage de bords, profils, coins, etc., elle doit être levée immédiatement après, pour éviter de soulever inutilement de la poussière et parce que la capacité de nettoyage de la brosse latérale est inférieure à celui obtenu avec la brosse centrale.

Pour un bon résultat, vider souvent le conteneur et tenir nettoyé le filtre en le faisant vibrer à l'aide des outils correspondants.

## 10. RICHTIGER GEBRAUCH UND RATSCHLÄGE

**WICHTIG :** Bevor Sie mit der Arbeit anfangen, überprüfen Sie die Anwesenheit von Seilen, Drähten, usw auf der Oberfläche: diese sind tatsächlich gefährlich und könnten die Staubschutz-Dichtungen beschädigen. Vor der Arbeit mit der Maschine müssen diese Gegenständen entfernt werden. Seien Sie vorsichtig, wenn Sie auf Bahnschienen oder Türschienen, usw fahren, weil diese den Staubschutz-Dichtungen die größten Schäden verursachen. Vermeiden Sie auf Pfützen zu fahren und, in Anwesenheit von feuchten Oberflächen, heben Sie die Bürsten auf. Sollte die Kehroberfläche, wegen der Menge oder Qualität des Materials oder Staubs, sehr schmutzig sein, empfehlen wir, zuerst "grob" zu kehren, ohne sich um das Ergebnis viel zu kümmern, dann, mit leerer Schublade und gut vibrierten Filtern, kehren Sie nochmal die grob gekehrte Oberfläche: das Ergebnis wird wie gewünscht sein. Danach, wenn die Maschine methodisch und gelegentlich gebraucht wird, ist es nicht mehr nötig, "grob" zu kehren. Die Seitenbürste soll ausschließlich für das Putzen von Kanten, Ecken und Profilen gebraucht werden, nach dem Putzen muß sie entfernt werden, um zu vermeiden, das zwecklose Aufheben von Staub und auch weil die Kehrwirkung von der Seitenbürste kleiner als die von der Hauptbürste ist Um gute Ergebnisse zu erreichen, muß man den Behälter sehr oft entleeren und den Filter mit den dazugehörenden Werkzeugen immer sauber halten.

## 10. USO CORRECTO Y CONSEJOS

**IMPORTANTE:** Antes de empezar el trabajo, hay que comprobar si en la superficie se encuentran cuerdas, hilos de corriente etc; éstos son peligrosos y podrían dañar las empaquetaduras antipolvo. Por lo tanto, hay que eliminarlos antes de empezar el trabajo con la máquina.

Tenga mucho cuidado al pasar sobre carriles, o guías de puertas etc. porque éstos son la fuente principal de daño para las empaquetaduras antipolvo.

Evite de pasar sobre charcos, si está en presencia de superficies húmedas, levante los cepillos.

Si la superficie que hay que limpiar está muy sucia por cantidad o calidad del material o polvo para recoger, aconsejamos que se efectúe antes un pasaje "de desbaste" sin cuidar demasiado el aspecto obtenido, por lo tanto con el cajón limpio y los filtros bien vibrados, repita los pasajes; así obtendrá el efecto deseado. Luego, utilizando metódica y oportunamente la máquina no necesitará de efectuar "el desbaste".

El cepillo lateral debe ser utilizado solo para la limpieza de bordes, perfiles, esquinas, etc., debe ser levantado luego después, para no levantar inútil polvo, y porque el efecto limpio del cepillo lateral siempre es inferior al efecto limpio del cepillo central. Para alcanzar un buen resultado, es necesario vaciar a menudo el contenedor y tener limpio el filtro sacudéndolo con los instrumentos idóneos.

## 11. INTERVENTIONS D'ENTRETIEN ORDINAIRE

Tenir sous contrôle le niveau d'huile hydraulique, pour éviter des surchauffages, il faut qu'il soit toujours à niveau.

Pour d'éventuels rembouragements, utiliser le type d'huile suivante: voir tableau en bas Fig.18.

En ce qui concerne les deux filtres à huile, leur substitution est prévue comme suit; pour le filtre réf. **R** fig.17 après les premières 50 heures, en suite toutes les 500 heures, tandis que pour le filtre réf. **Q** fig.17 la substitution est prévue toutes les 1000 heures, le filtre mentionné se trouve à l'intérieur du réservoir pourtant il faut ôter le couvercle en desserrant les huit vis avec la clé de 10, puis dévisser le filtre et le remplacer.

## 11. ORDENTLICHE WARTUNG

Der Stand des hydraulisches Öls muß immer unter Kontrolle gehalten werden; um Überhitzungen zu vermeiden, muß der Ölstand am richtigem Pegel sein Abb.18. Um eventuell nachzufüllen, benutzen Sie das folgende Öltyp: siehe Tabelle am Ende der Seite.

Was die zwei Ölfilter betrifft, müssen diese wie folgt ersetzt werden: der Filter Pos. **R** Abb.17 nach den ersten 50 Arbeitsstunden, dann je 500 Arbeitsstunden, während der Filter Pos. **Q** Abb.17 muss alle 1000 ersetzt werden: der soeben genannte Filter befindet sich im Tank, deshalb muß man den Deckel beim Auslösen der acht Schrauben mit einem 10mm-Schlüssel entfernen. Dann den Filter abschrauben und ihn ersetzen.

## 11. INTERVENCIONES DE MANUTENCIÓN ORDINARIA

Hay que tener bajo control el nivel del aceite hidráulico, para evitar sobrecalentamiento es necesario que esté siempre a nivel.

Para eventuales añadidos, utilice el siguiente tipo de aceite: vease tablero al fondo página Fig.18.

En lo que se refiere a los dos filtros de aceite, su remplazo está previsto como sigue: para el filtro ref. **R** fig.17 después de las primeras 50 horas, luego cada 500 horas, mientras que para el filtro ref. **Q** fig.17 su remplazo está previsto cada 1000 horas. El filtro mencionado arriba está al interior del depósito, por lo tanto hay que quitar la capa aflojando los ocho tornillos con la llave de 10, luego destornillar el filtro y remplazarlo.

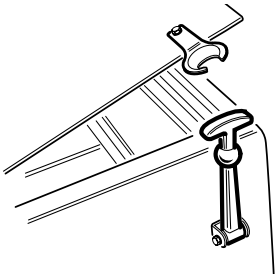
**1**

**IMPORTANTE:** Gli interventi di manutenzione ordinaria devono essere eseguiti indossando guanti, mascherina per evitare di inalare polveri nocive, occhiali. Prima di eseguire questa operazione spegnere il motore e togliere la chiave avviamento dal proprio alloggiamento.

**IMPORTANT:** The ordinary maintenance interventions must be carried out wearing gloves, anti-dust mask and goggles. Before carrying out this operation, switch off the motor and remove the ignition key from its housing.

**OPERAZIONE DA ESEGUIRE A MOTORE FERMO E FREDDO**

**OPERATION TO BE CARRIED OUT WITH IDLE AND COLD MOTOR**

**PULIZIA FILTRO POLVERE:**

**CLEANING THE DUST FILTER:**

Ogni 40/70 ore di lavoro, o quando necessita, controllare il filtro che si trova sotto il cofano, procedendo nel modo rappresentato dalle figure:

Every 40 to 70 working hours, or when necessary, check the filter under the bonnet, proceed as shown on the illustrations:

**1:** Sollevare il coperchio vano filtri, agendo sui ganci di blocco.

**1:** Lift the filter area lid, by acting on the locking hooks.

**2:** Staccare il connettore dello scuotifiltro.

**2:** Unplug the connector of the filter shaker.

**3:** Sbloccare i premi supporto filtro e togliere il filtro dalla propria sede. Pulirlo a fondo con aspirapolvere.

**3:** Unlock the filter bracket pressors and remove the filter from its seat. Clean it thoroughly with a vacuum cleaner.

**N.B.: PER IL MONTAGGIO DEL FILTRO, SEGUIRE LA SEQUENZA 3, 2, 1.**

**NOTE: REASSEMBLE THE FILTER ACCORDING TO THE SEQUENCE 3, 2, 1.**

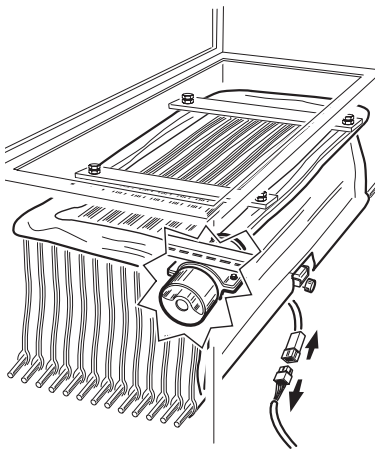
**19**

**IMPORTANT:** Les interventions d'entretien ordinaire doivent être exécutés en portant les gants, la masque pour éviter l'inhalation de poussières nuisibles, lunettes. Avant d'effectuer cette opération, arrêter le moteur et ôter la clé d'allumage de son logement.

### **OPÉRATION À EFFECTUER À MOTEUR ARRÊTÉ ET FROID**

#### **NETTOYAGE FILTRE POUSSIÈRE:**

Toutes les 40/70 heures de travail, ou quand nécessaire, vérifier le filtre qui se trouve sous le capot, selon la procédure illustrée:

**1:** Soulever le couvercle logement filtres, en agissant sur les crochets de blocage.

**2:** Déconnecter le connecteur du secoueur de filtre.

**3:** Débloquer les presseurs du support filtre et ôter le filtre de son logement. Le nettoyer à fond en se servant d'un aspirateur.

**N.B.: POUR LE MONTAGE DU FILTRE, SUIVRE LA SÉQUENCE 3, 2, 1.**

**WICHTIG :** Die ordentliche Wartung sinterventionen müssen mit Handschuhen, Schutzmaske und Schutzbrille durchgeführt werden. Bevor man diese Operation durchführt, muß man den Motor abstellen und den Zündschlüssel aus seinem Gehäuse wegnehmen.

### **DIESE OPERATION MUß MIT STILLSTEHENDEM UND KALTEM MOTOR DURCHGEFÜHRT WERDEN**

#### **REINIGEN DES STAUB-FILTERS:**

Alle 40 bis 70 Arbeitsstunden, oder wenn nötig, den Filter unter der Motorhaube, wie illustriert, kontrollieren:

**1:** Den Deckel des FilterRaums durchs Betätigen der Befestigungshaken aufheben

**2:** Den Verbinder des Filterschüttlers abtrennen

**3:** Die Klemmen der Filterhalterungen entlocken und den Filter aus seinem Sitz entfernen. Den Filter mit einem Staubsauger gründlich säubern.

**BEMERKUNG: DEN FILTER NACH DER REIHENFOLGE 3, 2, 1 EINBAUEN.**

**IMPORTANTE:** Las intervenciones de mantenimiento ordinario deben ser ejecutados con guantes, mascara para evitar la inhalación de polvos nocivos, gafas. Antes de ejecutar esta operación hay que apagar el motor y quitar la llave de puesta en marcha de su engargolado.

### **OPERACIÓN DE EJECUTAR A MOTOR PARADO Y FRIO**

#### **LIMPIEZA FILTRO POLVO:**

Cada 40/70 horas de trabajo, o cuando necesita, compruebe el filtro que está bajo el capó, según la procedura indicada en las ilustraciones:

**1:** Levante la capa vano filtrosi, actuando en los ganchos de bloqueo.

**2:** Destaque el conector del sacudidor.

**3:** Desbloquear los presores del soporte filtro y quitar el filtro de su sede. Limpiarlo a fondo con un aspirador.

**N.B.: PARA EL MONTAJE DEL FILTRO, SIGA LA SECUENCIA 3, 2, 1.**

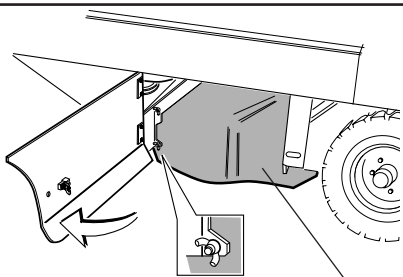

Part. A lato dx  
Part. B lato sx (non in vista)  
Part. C guarnizione posteriore

20

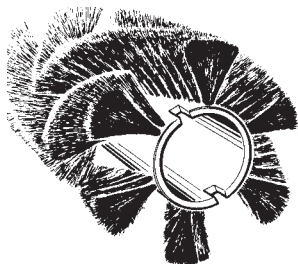

9 - 11 cm.

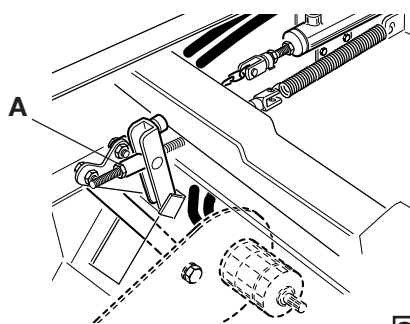

21

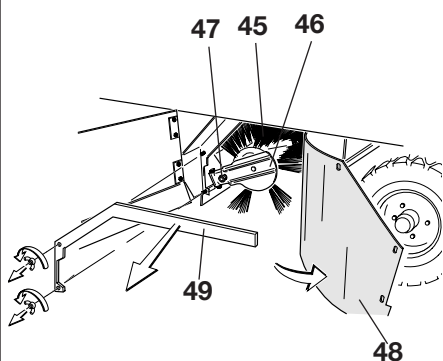

22

### **GUARNIZIONE ANTIPOLVERE:**

Ogni 40/70 ore di lavoro, verificare la condizione delle guarnizioni antipolvere che circondano la spazzola centrale ed all'occorrenza sostituirle Fig. 20.

### **ANTI-DUST SEAL:**

Every 40/70 working hours, check the condition of the anti-dust seals surrounding the central brush and, if necessary, replace them Fig. 20.

### **REGOLAZIONI E SOSTITUZIONI**

### **ADJUSTMENTS AND REPLACEMENTS**

#### **OPERAZIONE DA ESEGUIRE A MOTORE FERMO.**

#### **OPERATION TO BE CARRIED OUT WITH IDLE MOTOR**

#### **CONTROLLO DELLA TRACCIA DELLA SPAZZOLA CENTRALE:**

#### **CHECKING THE TRACE OF THE CENTRAL BRUSH:**

Riscontrando che la macchina non pulisce più perfettamente o tralascia sporco, occorrerà effettuare un controllo della traccia.

Should you notice that the machine does no longer sweep perfectly or some dirt is left, this means that a check of the trace has to be made.



Per controllare la traccia, lasciare la macchina ferma e, senza avanzare ne retrocedere, lasciarla ferma nello stesso punto per almeno 10/15 sec. Spegner il motore e far avanzare manualmente la macchina, fino a che sul pavimento sarà visibile la traccia che ha lasciato la spazzola centrale nella rotazione, come a lato.



To check the trace, leave the machine idle, without moving it forward or backward, on the same position for at least 10/15 sec. Switch off the motor and move the machine forward manually, until the trace left by the rotation of the central brush is visible, as shown by the drawing on the right.

Per la regolazione della spazzola centrale è sufficiente avvitare il dado -A- per diminuire la traccia, viceversa svitarlo se la si vuole aumentare.

To adjust the central brush, it is sufficient to tighten the nut -A- to diminish the trace, or to loosen it, if you wish to increase it.

#### **SMONTAGGIO SPAZZOLA CENTRALE:**

#### **REMOVING THE CENTRAL BRUSH:**

Procedere come segue. Fig. 22.

Proceed as follows. Fig. 22 .

- 1) Aprire lo sportello .
- 2) Rimuovere i quattro dadi a farfalla.
- 3) Estrarre il profilo di fermo part. 49.
- 4) Spostare la guarnizione sulla destra part. 48.
- 5) Rimuovere il pomello part. 47.
- 6) Estrarre il supporto mobile part. 46.
- 7) Estrarre la spazzola centrale.

- 1) Open the door .
- 2) Remove the four wing nuts.
- 3) Take out the stop profile part. 49.
- 4) Move the seal to the right part. 48.
- 5) Remove knob part. 47.
- 6) Take out the mobile bracket part. 46.
- 7) Take out the central brush.

Per rimontare la spazzola procedere con sequenza inversa.

To remount the brush proceed with reverse sequence.

## JOINT ANTI-POUSSIÈRE:

Toutes les 40/70 heures de travail, vérifier la condition des joints anti-poussière qui encerclent la brosse centrale et, si nécessaire, les remplacer Fig. 20.

## JOINT ANTI-POUSSIÈRE:

Toutes les 40/70 heures de travail, vérifier la condition des joints anti-poussière qui encerclent la brosse centrale et, si nécessaire, les remplacer Fig. 20.

## EMPAQUETADURA ANTIPOLVO:

Cada 40/70 horas de trabajo, hay que comprobar la condición de las empaquetaduras antipolvo que circundan el cepillo central y si necesario remplazarlas Fig. 20.

## RÉGLAGES ET SUBSTITUTIONS

### OPÉRATION À EXÉCUTER À MOTEUR ARRÊTÉ

#### CONTRÔLE DE LA TRACE DE LA BROSSE CENTRALE:

Si on s'aperçoit que la machine ne brosse plus parfaitement ou laisse de la saleté, il faut effectuer un contrôle de la trace.

 Pour vérifier la trace, laisser la machine arrêtée et, sans avancer ni reculer, la laisser arrêtée dans le même point pour au moins 10/15 sec. Arrêter le moteur et faire avancer la machine manuellement, jusqu'à voir sur le sol la trace laissée par la brosse centrale dans sa rotation, voir à côté.

Pour le réglage de la brosse centrale il suffit de serrer l'écrou -A- fig.19 pour diminuer la trace, viceversa desserrer si l'on veut l'augmenter.

#### DÉMONTAGE BROSSE CENTRALE

Procéder comme suit. Fig. 22.

- 1) Ouvrir la porte.
- 2) Enlever les quatre écrous papillon.
- 3) Ôter le profil d'arrêt part. 49.
- 4) Déplacer le joint sur la droite part. 48.
- 5) Ôter le pommeau part. 47.
- 6) Ôter le support mobile part. 46.
- 7) Ôter la brosse centrale.

Pour remonter la brosse, opérer à l'envers.

## RÉGLAGES ET SUBSTITUTIONS

### OPÉRATION À EXÉCUTER À MOTEUR ARRÊTÉ

#### CONTRÔLE DE LA TRACE DE LA BROSSE CENTRALE:

Si on s'aperçoit que la machine ne brosse plus parfaitement ou laisse de la saleté, il faut effectuer un contrôle de la trace.

 Pour vérifier la trace, laisser la machine arrêtée et, sans avancer ni reculer, la laisser arrêtée dans le même point pour au moins 10/15 sec. Arrêter le moteur et faire avancer la machine manuellement, jusqu'à voir sur le sol la trace laissée par la brosse centrale dans sa rotation, voir à côté.

Pour le réglage de la brosse centrale il suffit de serrer l'écrou -A- fig.19 pour diminuer la trace, viceversa desserrer si l'on veut l'augmenter.

#### DÉMONTAGE BROSSE CENTRALE

Procéder comme suit. Fig. 22.

- 1) Ouvrir la porte.
- 2) Enlever les quatre écrous papillon.
- 3) Ôter le profil d'arrêt part. 49.
- 4) Déplacer le joint sur la droite part. 48.
- 5) Ôter le pommeau part. 47.
- 6) Ôter le support mobile part. 46.
- 7) Ôter la brosse centrale.

Pour remonter la brosse, opérer à l'envers.

## AJUSTES Y SUSTITUCIONES

### OPERACIÓN DE EJECUTAR CON MOTOR PARADO

#### CONTROL DE LA TRAZA DEL CEPILLO CENTRAL:

Si se percibe que la máquina no limpia más perfectamente o deja suciedad, hay que efectuar el control de la traza.

 Para comprobar la traza, deje la máquina parada y, sin avanzar ni retroceder, la deje parada en el mismo punto al menos por 10/15 seg. Apague el motor y haga avanzar manualmente la máquina, hasta que en el suelo se pueda ver la traza que ha dejado el cepillo central en la rotación, como ilustrado al lado.

Para el ajuste del cepillo central es suficiente atornillar la tuerca -A- fig.19 para disminuir la traza, al contrario hay que destornillarla si se quiere aumentar.

#### DESMONTAJE CEPILLO CENTRAL

Hay que actuar como sigue. Fig. 22.

- 1) Abrir la puerta.
- 2) Aflojar las cuatro tuercas mariposa.
- 3) Sacar el perfil de paro part. 49.
- 4) Desplazar la empaquetadura a la derecha part. 48.
- 5) Quitar el pomo part. 47.
- 6) Sacar el soporte móvil part. 46.
- 7) Sacar el cepillo central.

Para montar de nuevo el cepillo, actuar con secuencia inversa.

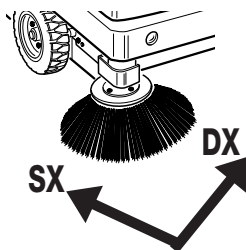
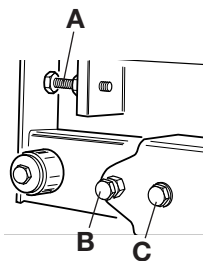

23

### REGOLAZIONE SPAZZOLA LATERALE

La vite pos.A Fig. 23 serve per la regolazione in altezza della spazzola pertanto quando si sarà usurata la spazzola si dovrà intervenire avvitando la vite.

La vite pos.B Fig. 23 serve per il brandeggio del braccio porta spazzola, avvitandola il braccio si sposta verso dx e viceversa svitandola si sposta verso sx.

La vite pos. C Fig.23 serve per caricare la molla di fermo spazzola.

### ADJUSTING THE LATERAL BRUSH

The screw pos. A Fig. 23 is used for the adjustment in height of the brush therefore, when this is worn out, you will have to intervene by tightening the screw .

The screw pos. B Fig. 23 controls the swinging of the brush holding arm, by tightening it, the arm moves to the right and by loosening it, the arm moves to the left.

The screw pos. C Fig.23 is used to load the brush stopping spring.

### 12. MANUTENZIONI STRAORDINARIE

#### ATTENZIONE:

Le manutenzioni straordinarie sono tutte quelle che non sono state menzionate nel libretto; pertanto esse dovranno essere eseguite da personale specializzato per l'assistenza preposto a tale scopo.



### 12. EXTRAORDINARY MAINTENANCE

#### CAUTION:

An extraordinary maintenance is a type of maintenance that is not described in this manual; in fact, they must be carried out by qualified maintenance personnel for this purpose.



### 13. MESSA FURI SERVIZIO

Togliere le batterie dal loro alloggiamento e conservarle in un luogo asciutto e ben aerato, per una buona durata delle batterie inutilizzate per un certo periodo di tempo occorre, provvedere alla carica ed eventualmente al rabbocco ogni 30/40 giorni.

Pulite la macchina in generale, pulite il filtro polvere e il cassetto.

### 13. GARAGING

Remove the batteries from their seat and store them in a dry and ventilated place. To ensure a good duration of the unused batteries over a certain period of time, you need to recharge them and, if necessary, refill them every 30/40 days.

Clean the machine overall, clean the anti-dust filter and the drawer.



### RÉGLAGE BROSSÉ LATÉRALE

La vis pos.A Fig. 23 sert pour le réglage en hauteur de la brosse, pourtant lorsqu la brosse sera usurée, on devra intervenir en serrant la vis.

La vis pos.B Fig. 23 sert pour le pivotement du bras porte-brosse, en la serrant le bras se déplace vers la droite et, en la desserrant, il se déplace vers la gauche.

La vis pos. C Fig.23 sert pour charger le ressort d'arrêt de la brosse.

### VERSTELLUNG DER SEITENBÜRSTE

Die Schraube Pos. A Abb. 23 verstellt die Höhe der Bürste deshalb muß man diese Schraube anschrauben, wenn die Bürste abgenutzt ist. Die Schraube Pos. B Abb. 23 verstellt die Schwenkung des Bürstehalterarmes, um ihn nach rechts zu bewegen, die Schraube anziehen, um ihn nach links zu bewegen, sie lösen.

Die Schraube Pos. C Abb. 23 ladet die Befestigungsfeder der Bürste.

### AJUSTE CEPILLO LATERAL

El tornillo pos.A Fig. 23 sirve para la regulación en altura del cepillo, por lo tanto, cuando el cepillo está usado, hay que intervenir apretando el tornillo. El tornillo pos.B Fig. 23 sirve para la oscilación del brazo porta cepillo, atornillandolo el brazo se desplaza hacia la derecha y viceversa destornillandolo se desplaza hacia la izquierda. El tornillo pos. C Fig.23 sirve para cargar el muelle de paro del cepillo.

## 12. ENTRETIENS EXTRAORDINAIRES

### ATTENTION:

Les entretiens extraordinaires sont tous ceux qui n'ont pas été mentionné dans ce manuel; pourtant ils devront être effectués par du personnel spécialisé pour l'assistance après-vente.



## 12. AUßERORDENTLICHE WARTUNGEN

### VORSICHT:

Die außerordentlichen Wartungen sind jene, die nicht in diesem Büchlein erwähnt worden sind; deshalb, müssen sie von Fachleute durchgeführt werden.



## 12. MANTENIMIENTOS EXTRAORDINARIOS

### ATENCIÓN:

Los mantenimientos extraordinarios son todos aquellos que no están mencionados en este manual; por lo tanto, debrán ser ejecutados por personal especializado en la asistencia prepuesto a este fin.



## 13. MISE HORS SERVICE

Ôter les batteries de leur logement, et les conserver dans un endroit sec et bien aéré. Pour assurer une bonne durata des batteries inutilisées pour une certaine période de temps, il faut les charger et éventuellement recharger tous les 30/40 jours.

Nettoyer la machine en général, nettoyer le filtre poussière et le tiroir.

## 13. WINTERLAGERUNG

Die Batterien von ihrer Kammer entfernen, und sie in einem trockenen belüfteten Ort lagern. Um die gelagerten Batterien lange Zeit benutzen zu können, muß man diese alle 30/40 Tage aufladen und eventuell auffüllen.

Die ganze Maschine zusammen mit den Staubfiltern und der Schublade sauber machen.

## 13. PUESTA FUERA DE SERVICIO

Quite las baterías de su sitio, y las conserve en un lugar seco y bien airado, para obtener una buena duración de las baterías inutilizadas por cierto período de tiempo, hay que, proveer a la carga y eventualmente al relleno cada 30/40 días.

Limpie la máquina en general, limpie lo filtro antipolvo y el cajón.

## 14. SMANTELLAMENTO / DEMOLIZIONE

**ATTENZIONE:** Lo smantellamento o demolizione deve essere eseguito del cliente in totale osservanza delle norme vigenti in materia, conferendo l'intera macchina o i pezzi che la compongono a ditte preposte per tali servizi.

## 15. SITUAZIONI DI EMERGENZA

In qualsiasi situazione di emergenza vi possiate trovare, per diverse ragioni, ad esempio: si è passati con la macchina in moto inavvertitamente su cavi di corrente presenti sul pavimento, i quali si sono attorcigliati alla spazzola centrale o laterale, si percepisce un rumore insolito proveniente dall'interno della macchina o del motore, si sono raccolti inavvertitamente materiali incandescenti o liquidi infiammabili, materiali chimici in genere, veleni cc. ecc.

### OCCORRE:

- 1) Disinserire la trazione lasciando il comando avanzamento-retromarcia.
- 2) Spegnerne il motore girando in senso antiorario la chiave dell'avviamento posta sul pannello comandi.
- 3) Avendo raccolto materiali sopraccitati il contenitore dovrà essere pulito munendosi di guanti e maschera per proteggere le vie respiratorie.

## 16. DIFETTI - CAUSE - RIMEDI

I difetti delle motospazzatrici **160 DK**, fondamentalmente possono essere 2, e cioè: la macchina fa polvere durante l'uso o tralascia sporco a terra; le cause possono essere tante ma con l'uso accorto e una buona manutenzione ordinaria non potranno verificarsi spesso, e quindi:

DIFETTI	CAUSE	RIMEDI
1) La macchina fa polvere.	1) - Filtro intasato. - Filtro danneggiato. - Filtro montato male.  - Guarnizioni in gomma danneggiate. - Utilizzate sempre la spazzola laterale.	1) - Scuoterlo con scuotifiltro ed all'occorrenza estrarlo e pulirlo a fondo. - Sostituirlo. - Alloggiarlo correttamente nella propria sede e chiudere gli appositi ganci.  - Sostituirle.  - Utilizzate la spazzola laterale solo nei bordi, profili, angoli.
2) La macchina tralascia sporco a terra.	2) La spazzola centrale non è regolata al meglio, o si è consumata. - Avete raccolto fili, corde, ecc. - Guarnizioni laterali danneggiate. - Cassetto di raccolta pieno.	2) Regolate la spazzola centrale verificando la "traccia". - Toglierle. - Sostituirle/a. - Vuotarlo.
3) La macchina a batteria non rende al meglio.	3) Batteria scarica o non completamente carica.  - Il caricabatterie non è quello consigliato.	3) Verificare il livello dell'elettrolito e procedere con un nuovo ciclo di carica completo. Usare un caricabatterie adeguato.

## 14. DISMANTLING / DEMOLITION

**CAUTION:** The dismantling or demolition must be executed by the customer in total observation of the laws in force on subject, by delivering the whole machine or its components to companies specialized in these services.

## 15. EMERGENCY SITUATIONS

In any kind of emergency situation such as, for example, if you have accidentally driven the sweeper over current-carrying cables on the floor which have wound around the central or side brush, or there are strange noises coming from inside the machine or motor, or you have accidentally picked up incandescent materials or flammable liquids, chemical products in general, poisons, etc.

### PROCEED AS FOLLOWS:

- 1) Disconnect the drive by letting go of the lever.
- 2) Switch the motor off, by turning the starter key on the control panel anticlockwise.
- 3) Remove all the materials that have been collected by means of safety gloves and, if necessary, a mask to protect your respiratory tracts.

## 16. TROUBLESHOOTING

Two main faults may occur with the **160 DK** power sweepers: the machine causes dust to rise during use or leaves dirt on the floor. There can be many reasons for these, but if the machine is used correctly and routine maintenance is carried out regularly, they cannot occur very often. Therefore:

DEFECTS	CAUSES	REMEDIES
1) The machine causes dust.	<ol style="list-style-type: none"><li>1) - Filter clogged. - Filter damaged. - Filter fitted badly.</li> <li>- Rubber dust flaps damaged. - You are constantly using the side brush.</li></ol>	<ol style="list-style-type: none"><li>1) - Shake it with the filter-shaker and if necessary take it out and clean it thoroughly. - Replace it. - Fit it correctly in place and close the hooks provided.</li> <li>- Replace them. - Use the side brush for edges, borders and corners.</li></ol>
2) The machine leaves traces of dirt on the floor.	<ol style="list-style-type: none"><li>2) The central brush is incorrectly adjusted or worn. - You have collected wires, string, etc.. - The side seals are damaged. - Collection box full.</li></ol>	<ol style="list-style-type: none"><li>2) Adjust the central brush checking its "track". - Remove them. - Replace it/them. - Empty it.</li></ol>
3) The battery-powered sweeper is not performing correctly.	<ol style="list-style-type: none"><li>3) Battery flat or not fully charged.  - The battery charger is not the recommended one.</li></ol>	<ol style="list-style-type: none"><li>3) Check the level of the electrolyte and carry out a new complete battery charging cycle. - Use an appropriate battery charger.</li></ol>

## 14. DEMANTELEMENT / DEMOLITION

**ATTENTION:** Le démantèlement ou démolition doit être effectué par l'utilisateur en totale observance aux normes en vigueur en matière, en conférant toute la machine ou des pièces composantes à des sociétés spécialisées pour ces services.

## 15. SITUATIONS D'URGENCE

Dans n'importe quelle situation d'urgence, pour plusieurs raisons, par exemple: si on est passé avec la machine en marche par inadvertance sur des câbles de courant posés sur le sol, et ceux-ci se sont enroulés au tour de la brosse centrale ou latérale, si on entend un bruit insolite provenant de l'intérieur de la machine ou du moteur, si on a ramassé par inadvertance des matières incandescentes ou des liquides inflammables, des matières chimiques en général, poisons etc. etc.

### IL FAUT:

- 1) Dèbrater la traction et relâchant le levier
- 2) Arrêter le moteur en tournant la clé de démarrage située sur le panneau commandes.
- 3) Ayant ramassé les matières mentionnées avant, le conteneur devra être nettoyé en se servant de gants et d'une masque pour protéger les voies respiratoires

## 16. DÉFAUTS- CAUSES - REMÈDES

Les défauts des balayeuses **160 DK**, fondamentalement peuvent être 2, c'est-à-dire: la machine fait de la poussière pendant l'emploi, ou laisse de la saleté au sol; les causes peuvent être nombreuses mais avec un emploi attentif et un bon entretien ordinaire, ceux-ci seront très rares:

DÉFAUTS	CAUSE	REMÈDES
1) La machine fait de la poussière.	1) - Filtre engorgé.  - Filtre abîmé. - Filtre monté mal.  - Joints en caoutchouc endommagés. - Utiliser toujours la brosse latérale.	1) - Le secouer avec le vibreur du filtre et si nécessaire le faire sortir et le nettoyer à fond. - Le remplacer. - Le loger correctement dans son logement et chiudere les crochets.  - Les remplacer.  - Utiliser la brosse latérale seulement dans les bords, profils, coins.
2) La machine laisse de la saleté au sol.	2) La brosse centrale n'est pas bien réglée, ou s'est consommée. - On a ramassé des fils, cordes, etc. - Joints latéraux endommagés. - Tiroir de ramassage plein.	2) Régler la brosse centrale en vérifiant la "trace". - Les ôter. - Les/le remplacer. - Le vider.
3) La machine à batterie ne rend pas au mieux.	3) Batterie déchargée ou non entièrement chargée.  - Le chargeur de batteries n'est pas celui recommandé.	3) Vérifier le niveau de l'électrolyte et procéder avec un nouveau cycle de charge complet Utiliser un chargeur de batteries adéquate.

## 14. ABBAU / DEMOLITION

**VORSICHT:** Die Abbau oder Demolition der Maschine muß vom Benutzer mit totaler Beachtung der geltenden Vorschriften durchgeführt werden, mit der Lieferung von der ganzen Maschine oder von Teilen der selben an darauf spezialisierten Firmen.

## 15. NOTFÄLLE

Auf irgendwelchem Notfall, zum Beispiel: man hat mit der Maschine versehentlich auf Stromkabel am Boden durchgefahren und diese um die Haupt- oder Seitenbürste aufgewickelt, man hört ein ungewöhnliches aus der Innenseite der Maschine oder Motor kommendem Lärm, oder man hat Glühmaterial oder eine entzündbare Flüssigkeit, oder Chemikalien, Gifte, usw versehentlich gekehrt,

### MUß MAN:

- 1) den Antrieb auskuppeln, indem man die Kontrolle für den Vorwärts-/Rückwärtsgang losläßt.
- 2) den Motor ausschalten, indem man den Startschlüssel am Schalttafel im Gegenuhrzeigersinn dreht.
- 3) wegen der Sammlung der o.g. Materialien, muß man den Behälter gesäubert werden, aber mit Schutzhandchuhen und Schutzmaske, um die Atemwege zu schützen.

## 16. DEFEKTE - URSACHEN - LOSUNGEN

Die Defekte der Kehrmaschinen **160 DK** können gründlich zwei sein, d.h.: die Maschine hebt Staub bei dem Gebrauch, oder läßt Verschmutzung am Boden; es kann viele Ursachen geben, aber mit einer sorgfältigen Verwendung und einer guten ordentlichen Wartung sind die Defekte selten, und zwar:

DEFEKTE	URSACHEN	LÖSUNGEN
1) Die Maschine hebt Staub.	1) - Verstopfter Filter.  - Beschädigter Filter. - Falsch eingebauter Filter.  - Beschädigte Gummi-Dichtungen. - Immer die Seitenbürste verwenden.	1) - Mit dem Filterschüttler ihn schütteln und, wenn nötig, ihn herausnehmen und gründlich sauber machen. - Ihn wechseln. - Ihn genau in die Kammer einbauen und mit den Haken schließen. - Sie wechseln. - Benutzen Sie die Seitenbürste in Kanten, Profilen, Ecken.
2) Die Maschine läßt Verschmutzung am Boden.	2) Die Hauptbürste ist nicht optimal verstellt oder ist abgenutzt. Man hat Drähte, Seilen, usw gekehrt. Die seitlichen Dichtungen sind beschädigt. Die Schublade ist voll.	2) die Hauptbürste durch die "Spur" prüfen. Alles wegnehmen. Sie wechseln. Sie entleeren.
3) Die Leistung der batteriebetriebenen Maschine ist nicht optimal.	3) Die Batterie ist aufgeladen oder nicht völlig geladen. Das Batterieladegerät ist nicht wie empfohlen.	3) Den Stand der saueren Lösung prüfen und einen neuen kompletten Aufladezyklus starten. Ein richtiges Aufladegerät benutzen.

## 14. DESMANTELAMIENTO / DEMOLICIÓN

**ATENCIÓN: El desmantelamiento o demolición debe ser ejecutado dal cliente en total observancia de las normas vigentes en materia, conferendo la máquina entera o las piezas que la componen a empresas prepuestas para estos .**

## 15. SITUACIONES DE EMERGENCIA

En cualquier situación de emergencia se pueda encontrar, por varias razones, por ejemplo se ha pasado inadvertidamente sobre cables de corriente presentes en el suelo, que se han enrollado al cepillo central o lateral, se percibe un ruido extraño proveniente del interior de la máquina o del motor, se han recolectado inadvertidamente unos materiales candentes o líquidos inflamables, materiales químicos en general, venenos, etc. etc.

### HAY QUE:

- 1) Desconectar la tracción dejando la leva
- 2) Apagar el motor girando en sentido contrario a las agujas del reloj la llave de puesta en marcha en el panel de mandos.
- 3) Despues de recogido los materiales mencionados arriba, quitar el contenedor ( cajón ), limpiarlo utilizando guantes y mascara para proteger las vías respiratorias

## 16. DEFECTOS - CAUSAS - REMEDIOS

Los defectos de las barredoras **160 DK**, fundamentalmente pueden ser 2, es decir: la máquina hace polvo durante el uso, o deja sucio el suelo; las causas pueden ser muchas pero con el uso atento y una buena manutención ordinaria no podrán ocurrir a menudo, de toda manera:

DEFECTOS	CAUSAS	REMEDIOS
1) La máquina hace polvo.	1) - Filtro obstruido.  - Filtro dañado. - Filtro montado mal.  - Empaquetaduras de goma dañadas. - Utilize siempre el cepillo lateral.	1) - Hay que sacudirlo con el sacudidor y si necesario sacarlo y limpiarlo a fondo. - Reemplazarlo. - Ponerlo correctamente en su propia sede y cerrar los ganchos.  - Reemplazarlas. - Utilizar el cepillo lateral solo en los bordes, perfiles, rincones.
2) La máquina deja sucio el suelo.	2) El cepillo central no está ajustado a lo más, o se ha gastado. - Han sido recolectados hilos, cuerdas, etc. - Empaquetaduras laterales dañadas. - Cajón de recogida lleno.	2) Ajustar el cepillo central comprobando la "traza". - Quitarlas. - Reemplazarlas/a. - Vaciarlo.
3) La máquina a batería no rinde a lo más.	3) Batería descargada o no completamente cargada.  - El cargabaterías no es aquello recomendado.	3) Comprobar el nivel del electrolito y proceder con un nuevo ciclo de carga completo. Utilizar un cargabaterías adecuado.

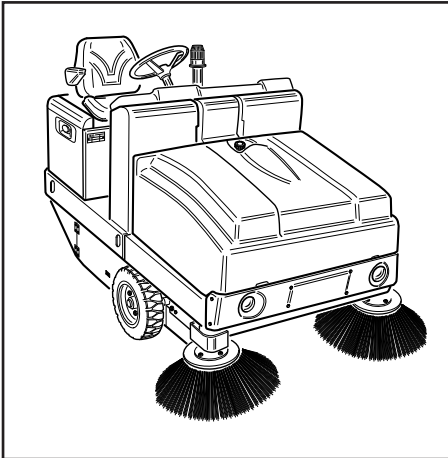

**ESPLOSO CON ELENCO  
 RICAMBI**

Questa sezione comprende 5 tavole raffiguranti l'esploso della macchina (numerate da 1 a 5) e l'elenco ricambi con i relativi codici.

Quando si desidera ordinare ricambi, specificare con esattezza:

**EXPLODED VIEW +  
 SPARE PARTS LIST**

This section includes 5 tables with the exploded view of the machine (numbered from 1 to 5) and the spare parts list with relevant part numbers.

When placing an order for spare parts, please always specify:

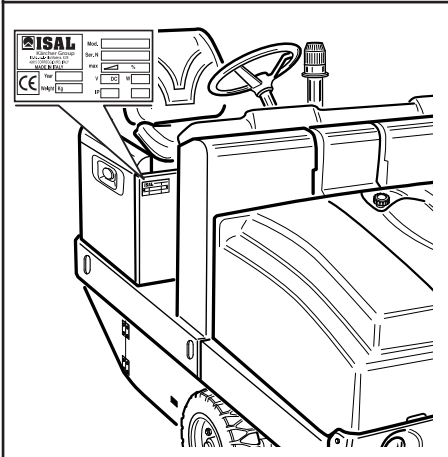

1) Il modello ed il numero di serie della spazzatrice rilevabile dalla apposita targhetta.

1) Machine model and machine serial number printed on the machine plate located as shown.

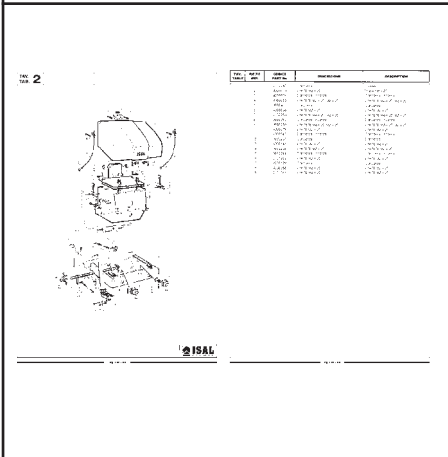

2) Il codice ISAL e la descrizione del ricambio richiesto rilevabile dagli elenchi delle pagine seguenti.

2) ISAL part number and description of the required spare part as shown on the following pages.

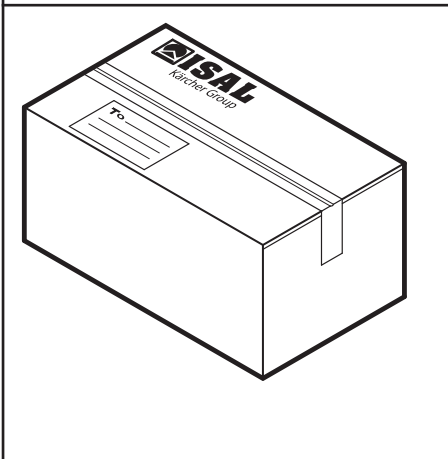

3) La quantità richiesta.

3) The quantity of the part you need.

4) Le istruzioni di spedizione (indirizzo, mezzo di trasporto, ecc.).

4) Definitive shipping instructions (address, means of transport, etc.).

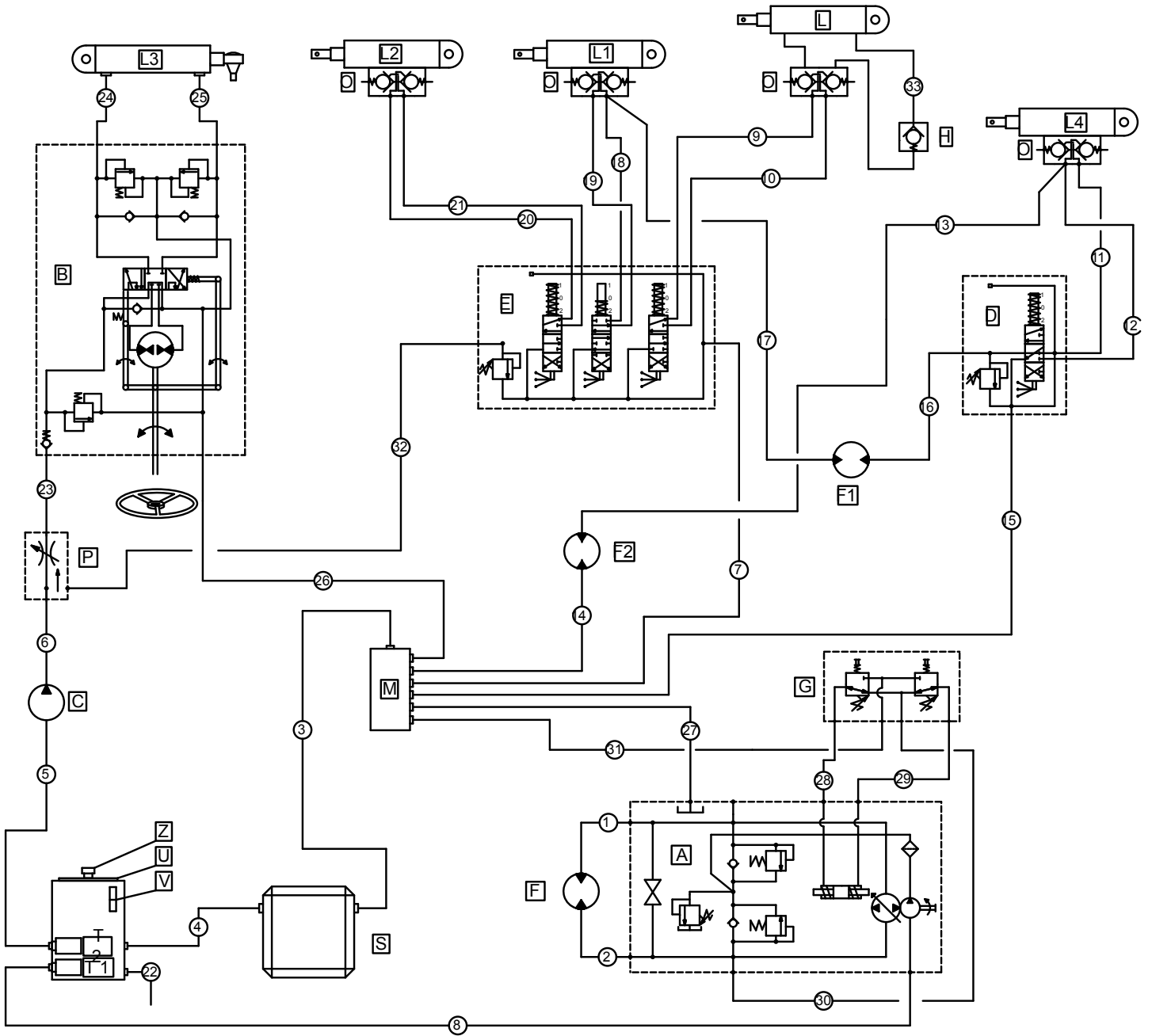



33	Tubo da valvola unidirezionale a cilindro sollevamento	Hydraulic pipe from one-way valve to lifting cylinder
32	Tubo da valvola prioritaria a distributore 3 leve	Hydraulic pipe from priority valve to 3 element distributor
31	Tubo da pedipolatore a raccoglitore olio	Hydraulic pipe from pedal to oil collector
30	Tubo da pedipolatore a pompa PV	Hydraulic pipe from pedal to Variable Pump
29	Tubo da pedipolatore a pompa PV	Hydraulic pipe from pedal to Variable Pump
28	Tubo da pedipolatore a pompa PV	Hydraulic pipe from pedal to Variable Pump
27	Tubo da pompa PV a raccoglitore olio	Hydraulic pipe from Variable Pump to oil collector
26	Tubo da idroguida a raccoglitore olio	Hydraulic pipe from hydroguide to oil collector
25	Tubo da idroguida a cilindro sterzo	Hydraulic pipe from hydroguide to power steering cylinder
24	Tubo da idroguida a cilindro sterzo	Hydraulic pipe from hydroguide to power steering cylinder
23	Tubo da valvola prioritaria a idroguida	Hydraulic pipe from priority valve to power steering
22	Tubo scarico serbatoio olio	Oli tank drain hose
21	Tubo da distributore 3 leve a cilindro flap	Hydraulic pipe from 3 element distributor to flap cylinder
20	Tubo da distributore 3 leve a cilindro flap	Hydraulic pipe from 3 element distributor to flap cylinder
19	Tubo da distributore 3 leve a cilindro spazz.centrale	Hydraulic pipe from 3 element distributor to main broom cylinder
18	Tubo da distributore 3 leve a cilindro spazz.centrale	Hydraulic pipe from 3 element distributor to main broom cylinder
17	Tubo da cilindro spazz.centrale a motore spazz.centrale	Hydraulic pipe from main broom cylinder to main broom hydraulic motor
16	Tubo da distributore una leva a motore spazz.centrale	Hydraulic pipe from single distributor to main broom hydraulic motor
15	Tubo da distributore una leva a raccoglitore olio	Hydraulic pipe from single distributor to oil collector
14	Tubo da motore spazz.laterale a raccoglitore olio	Hydraulic pipe from side motor cylinder to oil collector
13	Tubo da cilindro spazz.laterale a motore spazz.laterale	Hydraulic pipe from side broom cylinder to side motor cylinder
12	Tubo da distributore una leva a cilindro spazz.laterale	Hydraulic pipe from single distributor to side broom cylinder
11	Tubo da distributore una leva a cilindro spazz.laterale	Hydraulic pipe from single distributor to side broom cylinder
10	Tubo da distributore 3 leve a cilindro contenitore	Hydraulic pipe from 3 element distributor to lifting cylinder for container
9	Tubo da distributore 3 leve a cilindro contenitore	Hydraulic pipe from 3 element distributor to lifting cylinder for container
8	Tubo da serbatoio olio a pompa PV	Hydraulic pipe from oil tank to variable pump
7	Tubo da distributore 3 leve a raccoglitore olio	Hydraulic pipe from 3 element distributor to oil collector
6	Tubo da valvola prioritaria a pompa ingranaggi	Hydraulic pipe from priority valve to gear pump
5	Tubo da serbatoio olio a pompa ingranaggi	Hydraulic pipe from oil tank to gear pump
4	Tubo da scambiatore a serbatoio olio	Hydraulic pipe from heat exchanger to oil tank
3	Tubo da raccoglitore a scambiatore	Hydraulic pipe from collector to heat exchanger
2	Tubo da pompa PV a motore ruota	Hydraulic pipe from Variable Pump to wheel hydraulic motor
1	Tubo da pompa PV a motore ruota	Hydraulic pipe from Variable Pump to wheel hydraulic motor
Pos.	Descrizione	Description

Z	Tappo riempimento olio	Filler cap
V	Indicatore livello olio	Oil level indicator
U	Coperchio serbatoio	Tank cap
T2	Filtro olio 25M	Oil filter 25M
T1	Filtro olio 10M	Oil filter 10M
S	Scambiatore olio	Oil exchanger
P	Valvola prioritaria	Priority valve
O	Valvola di blocco pilotata	Lockyng valve
M	Collettore olio	oil collector
L4	Cilindro spazzola laterale destro	Right side brush cylinder
L3	Cilindro sterzo	Steer cylinder
L2	Cilindro flap	Flap cylinder
L1	Cilindro spazzola centrale	Main brush cylinder
L	Cilindro contenitore	Container cylinder
H	Valvola unidirezionale	Unidirectional valve
G	Pedipolatore	Pedal
F2	Motore spazzola destra	Right side brush motor
F1	Motore spazzola centrale	Main brush motor
F	Motore ruota	Wheel motor
E	Distributore tre leve	3 lever distributor
D	Distributore monoleva	1 lever distributor
C	Pompa ingranaggi	Gear pump
B	Idroguida	Hydroguide
A	Pompa portata variabile	Variable capacity pump
Pos.	Descrizione	Description



# IMPIANTO ELETTRICO - ELECTRIC SYSTEM

01	SA01- Blocchetto avviamento	01	SA01- Ignition key
02	FU13- Fusibile generale	02	FU13- Main fuse
03	GB01- Batteria 12V	03	GB01- Battery 12V
04	G01- Alternatore	04	G01- Alternator 12 V
05	M01- Motorino avviamento	05	M01- Starter motor
06	P01- Strumento multifunzione	06	P01- Instrument
07	FU01- Fusibile sicurezza avviamento	07	FU01- Safety starter fuse
08	Sw01- Micro sicurezza avviamento	08	Sw01- Safety starter switch
09	KA01- Relè candele (D version)	09	KA01- Glow plugs relay (D version)
10	K1/3- Candele (D version)	10	K1/3- Glow plugs (D version)
11	KA02- Relè avviamento	11	KA02- Starter relay
12	L01- Solenoide (D version)	12	L01- Solenoid (D version)
13	FU02- Fusibile solenoide	13	FU02- Solenoid fuse
14	KA03- Relè sicurezza sedile	14	KA03- Safety seat relay
15	Sw03- Micro sedile	15	Sw03- Seat switch
16	CK01- Centralina candele (D version)	16	CK01- Glow plugs control unit (D version)
17	FU03- Fusibile spia candele	17	FU03- Glow plugs light fuse
18	FU04- Fusibile sensore retro	18	FU04- Reverse sensor fuse
19	KA05- Relè cicalino retromarcia	19	KA05- Reverse buzzer relay
20	HA01- Cicalino retromarcia	20	HA01- Reverse buzzer
21	FU05- Fusibile strumento	21	FU05- Instrument fuse
22	BP01- Bulbo olio	22	BP01- Oil switch
23	BT01- Bulbo acqua	23	BT01- Water switch
24	BP03- Bulbo filtro aria	24	BP03- Air filter switch
25	SL01- Indicatore livello carburante (D version)	25	SL01- Fuel level indicator (D version)
26	FU06- Fusibile aspirazione	26	FU06- Suction fuse
27	KA04- Relè aspirazione	27	KA04- Suction relay
28	M02- Motore aspirazione	28	M02- Suction motor
29	FU07- Fusibile scuotifiltro	29	FU07- Shaker filter fuse
30	SA03- Interruttore aspirazione - scuotifiltro	30	SA03- Suction fan /shaker filter switch
31	M03- Motore scuotifiltro	31	M03- Shaker filter motor
32	FU08- Fusibile lampeggiante	32	FU08- Beacon fuse
33	HL01- Lampeggiante	33	HL01- Beacon
34	FU09- Fusibile avvisatore acustico	34	FU09- Horn fuse
35	SA04- Pulsante avvisatore acustico	35	SA04- Horn switch
36	HA02- Avvisatore acustico	36	HA02- Horn
37	FU10- Fusibile luci	37	FU10- Light fuse
38	SA05- Interruttore luci	38	SA05- Light switch
39	HL02- Luce posizione	39	HL02- Position light
40	HL03- Luce posizione	40	HL03- Position light
41	HL04- Fanale anteriore	41	HL04- Front light
42	HL05- Fanale anteriore	42	HL05- Front light
43	FU11- Fusibile pompa acqua	43	FU11- Water pump fuse
44	SA06- Interruttore pompa acqua (OPT)	44	SA06- Water pump switch (OPT)
45	M04- Pompa acqua (OPT)	45	M04- Water pump (OPT)
46	FU12- Fusibile lavavetro	46	FU12- Windscreen washer fuse
47	SA07- Pulsante lavavetro (OPT)	47	SA07- Windscreen washer switch (OPT)
48	M05- Pompa lavavetro (OPT)	48	M05- Windscreen washer pump (OPT)
49	SQ01- Sensore retromarcia	49	SQ01- Reverse sensor
50	YV01- Elettrovalvola gas (LPG version)	50	YV01- Gas solenoid (LPG version)
51	YV02- Elettrovalvola carburatore (LPG version)	51	YV02- Carburettor solenoid (LPG version)
52	BR01- Sensore giri (LPG version)	52	BR01- RPM sensor (LPG version)
53	E04- Centralina accensione (LPG version)	53	E04- Control unit (LPG version)
54	E01- Candela accensione (LPG version)	54	E01- Spark ignition (LPG version)
55	E02- Candela accensione (LPG version)	55	E02- Spark ignition (LPG version)
56	E03- Candela accensione (LPG version)	56	E03- Spark ignition (LPG version)
57	L03- Bobina alta tensione (LPG version)	57	L03- High voltage coil (LPG version)
58	L04- Bobina alta tensione (LPG version)	58	L04- High voltage coil (LPG version)
59	L05- Bobina alta tensione (LPG version)	59	L05- High voltage coil (LPG version)
60	E05- Centralina sicurezza gas (LPG version)	60	E05- Safety control unit gas (LPG version)
61	M06- Motore tergicristallo (OPT)	61	M06- Wiper motor (OPT)
62	SA02- Luce cabina (OPT)	62	SA02- Cabin light (OPT)
63	KA06- Relè timer scuotifiltro automatico (OPT)	63	KA06- Timer automatic shaker filter (OPT)
64	KA07- Relè scuotifiltro (OPT)	64	KA07- Shaker filter relay (OPT)

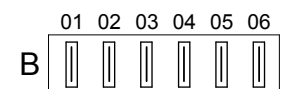
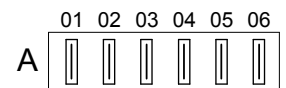

POSIZIONE FUSIBILI  
FUSES POSITION

Pos.	Rif.	Valore	Descrizione
01 A	07	3 A	FU01 sicurezza avviamento
02 A	13	10 A	FU02 solenoide/accensione
03 A	17	7,5 A	FU03 spia candele/cen. gas/E.V. carburatore
04 A	18	5 A	FU04 sensore retromarcia/tettuccio
05 A	21	3 A	FU05 strumento
06 A	25	25 A	FU06 aspirazione
01 B	29	25 A	FU07 scuotifiltro
02 B	32	5 A	FU08 lampeggiante
03 B	39	10 A	FU09 avvisatore acustico
04 B	37	15 A	FU10 luci
05 B	43	10 A	FU11 pompa acqua
06 B	46	7,5 A	FU12 lavavetro
	02	60 A	FU13 generale

Pos.	Rif.	Value	Function
01 A	07	3 A	FU01 safety starter
02 A	13	10 A	FU02 solenoid/starter
03 A	17	7,5 A	FU03 glow plugs light/gas control unit/carburettor solenoid
04 A	18	5 A	FU04 reverse sensor/roof
05 A	21	3 A	FU05 instrument
06 A	25	25 A	FU06 suction
01 B	29	25 A	FU07 shaker filter
02 B	32	5 A	FU08 beacon light
03 B	39	10 A	FU09 horn
04 B	37	15 A	FU10 light
05 B	43	10 A	FU11 water pump
06 B	46	7,5 A	FU12 windscreen washer
	02	60 A	FU13 main

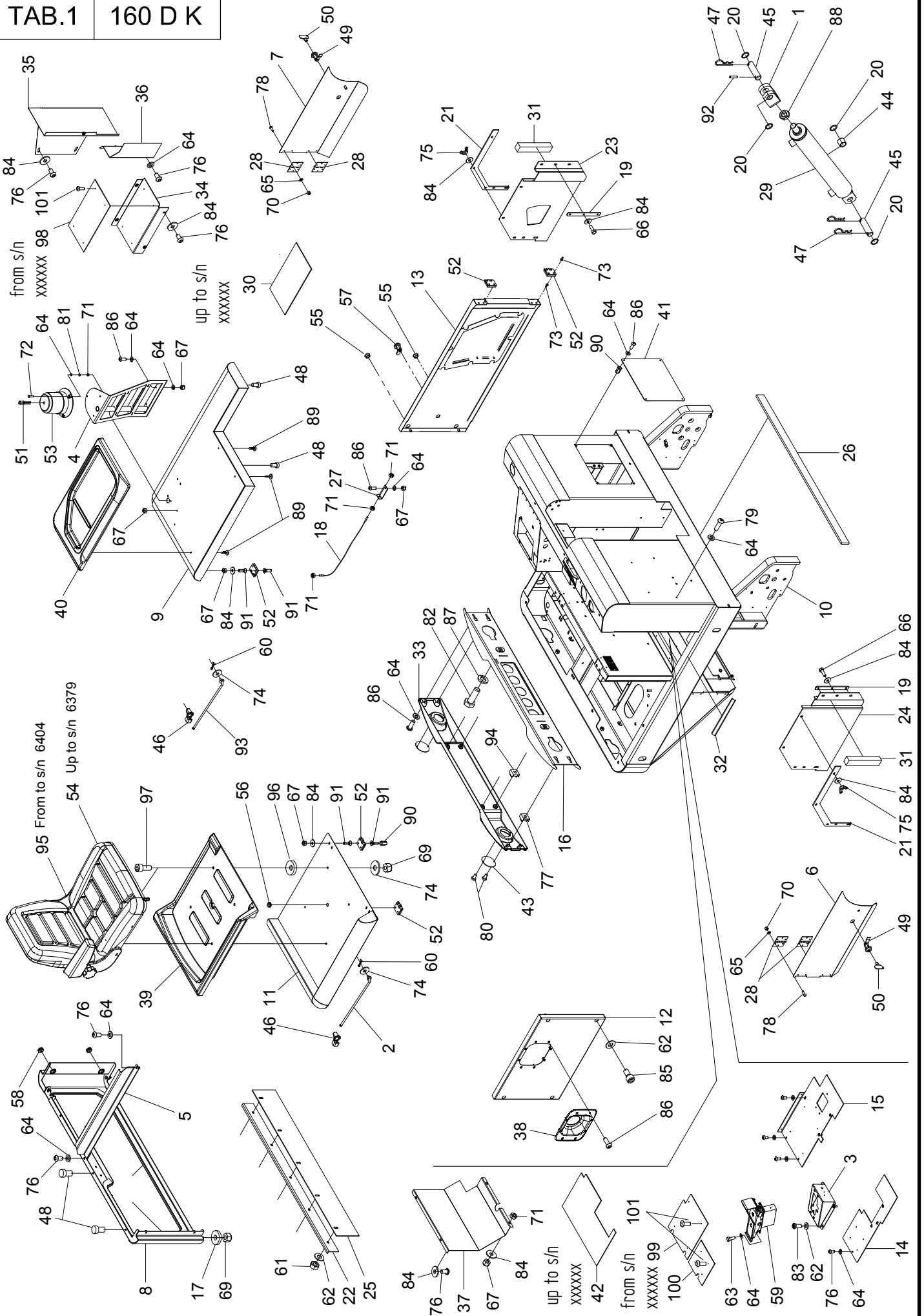

TAB.	Part Nr	DENOMINAZIONE	Q.ty	Description
1	1	2101857	FORCELLA CILINDRO SOLLEVAMENTO	1 Lifting cylinder fork
1	2	2103285	ASTA SUPPORTO COFANO	1 Seat bonnet rod
1	3	2109880	SUPPORTO PEDIPLATTORE	1 Pedal support
1	4	2110101	SUPPORTO LAMPEGGIANTE	1 Rotating flash support
1	5	2110685	CORRIMANO "C"	1 Handrail
1	6	2110726	SPORTELLO DX SPAZZOLA CENTRALE	1 Right door main broom
1	7	2110727	SPORTELLO SX SPAZZOLA CENTRALE	1 Left door main broom
1	8	2111340	CARTER POSTERIORE	1 Rear crankcase
1	9	2111338	COFANO MOTORE	1 Bonnet
1	10	2111149	TELAIO 160	1 Chassis
1	11	2111164	COFANO SEDILE "C"	1 Seat crankcase
1	12	3011166	CARTER LATO SEDILE	1 Seat side crankcase
1	13	2111168	CARTER LATO MOTORE	1 Engine side crankcase
1	14	3011381	PEDANA DX	1 Right platform
1	15	3011382	PEDANA SX	1 Left platform
1	16	2111175	PARAURTI POSTERIORE	1 Rear bumper
1	17	3000111	RONDELLA D.8,5 X 23,5 X 4	2 Washer 8,5x23,5x4/Galvanized
1	18	3000294	CAVO PER COFANO	1 Steel cable for bonnet
1	19	3001317	FERMAGOMMA SULLE RUOTE	2 Rubber fastener
1	20	3001501	RONDELLA DI SPESSORAMENTO	4 Washer
1	21	3001661	FLANGIA MOBILE SPAZZOLA CENTRALE	2 Movable flange main broom
1	22	3001903	ANGOLARE SOSTEGNO GOMMA	1 Rubber locking angular
1	23	3001931	FLAP LATERALE SX	1 Left dust flap
1	24	3001932	FLAP LATERALE DX	1 Right dust flap
1	25	3002260	FLAP POSTERIORE	1 Rear flap
1	26	3002750	GOMMA LUCIDA 45X10X1050	1 Gasket 45x10x1050
1	27	3003785	PIATTO FERMO COFANO MOTORE	1 Flat hood latch
1	28	3007297	CERNIERA "STANLEY"	4 Stanley hinge
1	29	3008258	CILINDRO SOLLEVAMENTO CONT.	1 Lifting cylinder for container
1	30	3008264	PEDANA CENTRALE (Fino a metricola xxxxxx)	1 Central platform (up to s/n xxxxxx)
1	31	3008362	PROFILO MUSSE 35X30X200	2 Gasket 30x35x200
1	32	3008768	NASTRO ANTISDRUCCIOLO L:250MM	1 Anti-skid tape L=250 mm
1	33	3010779	PLASTICA PARAURTI POSTERIORE	1 Plastic rear bumper
1	34	3010802	FONDO COPERTURA CRUSCOTTO	1 Cover plate
1	35	3010803	PARETE DI COPERTURA	1 Wall covering
1	36	3010804	CARTER COPRI TUBI	1 Casing pipe cover
1	37	3010806	LAMIERA DI COPERTURA	1 Cover plate
1	38	3010895	BOCCHETTONE GASOLIO	1 Fuel filler
1	39	3010896	BASE SEDILE	1 Seat base
1	40	3010897	PORTA OGGETTI	1 Storage
1	41	3011024	COPERCHIO ISPEZIONE POMPA	1 Cover pump inspection
1	42	3011177	PEDANA DI CALPESTIO	1 Platform
1	43	3011178	COPERTURA FANALI POSTERIORE	2 Tail end
1	44	4200622	BUSSOLA K4 20 X 23 X 20	1 Socket K4 20x23x20
1	45	4200634	PERNO D.20X71	2 Pin D.20x71
1	46	4200697	FERMO PER COFANO	2 Bonnet stop
1	47	4200744	COPPIGLIA A MOLLA CADMIATA	3 Cotter pin
1	48	4200749	TAPPO 8,5X20 CON BATTUTA	4 Cap 8,5x20
1	49	4200834	CHIUSURA VISE ACTION	2 Vise action lock
1	50	4200835	CHIAVE PER CHIUSURA	2 Locking key
1	51	4200919	LAMPADA LAMPEGGIANTE FLASH	1 Lamp Flasher
1	52	4201358	CERNIERA DIRAK FORATURA 30 X 55	6 Hinge
1	53	4201577	LAMPEGGIANTE FLASH 10-100 V	1 Rotating flash 10-100 V
1	54	4201707	SEDILE (Fine a matricola 6379)	1 Seat (up to s/n 6379)
1	55	4201731	TAPPO IN PLASTICA PER FORO Ø22	2 Plastic cap
1	56	4201757	PASSACAVO 18 X 16 X 3,5	1 Cable holder
1	57	4210808	CHIUSURA VISE ACTION DRIITA	1 Vise action lock
1	58	4210810	PASSACAVO APERTO Ø22 FORO Ø10	2 Cable holder
1	59	4210864	PEDIPLATTORE	1 Control pedal
1	60	4300013	COPPIGLIA ACC.UNI1336 D.2 X 15	2 Pin D.2x15 ISO 1234/Galvanized
1	61	4300029	DADO MEDIO M8 UNI 5588-6S ZINC.	5 Hexagon nut M8 ISO 4032/Galvanized
1	62	4300036	RONDELLA D.8,4 X 17 UNI 6592 ZINC.	13 Flat washer 8,4x17 ISO 7089 Galvanized
1	63	4300047	VITE TE M6X16 UNI5739 ZINC.	4 Hexagon screw M6x16 ISO 4017/Galvanized
1	64	4300048	RONDELLA D.6,4 X 12 UNI 6592 ZINC.	39 Flat washer 6,4x12 ISO 7089 Galvanized
1	65	4300049	RONDELLA D.4,3 X 9 UNI 6592 ZINC.	16 Flat washer 4,3 x 9 ISO 7089 Galvanized
1	66	4300050	VITE TE M6 X 20 UNI 5739 - 8.8 ZINC.	6 Hexagon screw M6x20 ISO 4017/Galvanized
1	67	4300051	DADO M6 AUTOFRENANTE UNI 7473 ZINC.	16 Hexagon self-locking nut M6 ISO 7040
1	68			
1	69	4300053	DADO M8 AUTOFRENANTE UNI 7473 ZINC.	6 Hexagon self-locking nut M8 ISO 7040
1	70	4300056	DADO M4 AUTOFRENANTE UNI 7473 ZINC.	16 Hexagon self-locking nut M4 ISO 7040
1	71	4300079	DADO MEDIO M6 UNI 5588-6S ZINC.	8 Hexagon nut M6 ISO 4032/Galvanized
1	72	4300087	VITE TE M6X25 ZINC.	3 Hexagon screw M6x25 ISO 4017/Galvanized
1	73	4300116	VITE TSPEI M6X16	8 Socket head flat countersunk M6x16 ISO 10642/Galvanized
1	74	4300126	RONDELLA D.8 X 24 UNI 6593 ZINC.	6 Flat washer large series 8 x 24 ISO 7093 Galvanized
1	75	4300134	DADO AD ALETTE M6 ZINCATO UNI5448	8 Wing nut M6 DIN 315 Galvanized
1	76	4300148	VITE TBEI M6 X 10 UNI 7380 ZINC.	18 Hexagon socket button cup screw M6x10 ISO 7380/Galvanized
1	77	4300155	DADO IN GABBIA M6	4 Cage nut M6
1	78	4300158	VITE TBEI M4 X 12 UNI7380	16 Hexagon socket button cup screw M4x12 ISO 7380/Galvanized
1	79	4300173	VITE TBEI 6 X 20 ISO 7380 ZINC.	2 Hexagon socket button cup screw M6x20 ISO 7380/Galvanized
1	80	4300188	VITE AUTOFILETTANTE 3,9 X 9,5	4 Self-tapping screw 3,9x9,5
1	81	4300192	RONDELLA GROOVER D.6	3 Split washer D.6 DIN 127/ Galvanized
1	82	4300204	VITE TE M10 X 30 UNI 5739 - 8.8 ZINC.	2 Hexagon screw M10x30 ISO 4017/Galvanized
1	83	4300222	VITE TBEI M8X20 UNI7380 ZINC.	4 Hexagon socket button cup screw M8x20 ISO 7380/Galvanized
1	84	4300224	RONDELLA D.6,4 X 18 UNI 6593 ZINC.	33 Flat washer large series 6,4 x 18 ISO 7093 Galvanized
1	85	4300246	VITE TCEI M8 X 16 UNI 5931 ZINC.	4 Socket head cup screw M8x16 ISO4762 Galvanized
1	86	4300247	VITE TBEI M6 X 15 UNI 7380 ZINC.	25 Hexagon socket button cup screw M6x15 ISO 7380/Galvanized
1	87	4300256	RONDELLA GROOVER D.10 UNI 1762 ZINC.	2 Split washer D.10 DIN 127/ Galvanized
1	88	4300257	DADO BASSO M20 X 1,5 UNI 5589	1 Nut M20x1,5 ISO 4035/Galvanized
1	89	4300379	VITE AUTOFILETTANTE 4,8X19 NERA	4 Self-tapping screw 4,8x19
1	90	4300407	RIVETTO A STRAPPO ESAGONALE M6	8 Rivet M6
1	91	4300437	VITE TSPEI M6 X 20 UNI 5933 - 8.8 ZINC	16 Socket head flat countersunk M6x20 ISO 10642/Galvanized
1	92	4300480	SPINA ELASTICA 6 X 30 INOX DIN 1481	1 Spring pin D.6x30 ISO 8752 Stainless steel
1	93	2102529	ASTA SUPPORTO COFANO	1 Seat bonnet rod
1	94	4312235	DADO IN GABBIA M6	4 Cage nut M6
1	95	4200373	SEDILE (Da matricola 6404)	1 Seat( From to s/n 6404)
1	96	3000111	RONDELLA PER ALBERO	4 Flat washer
1	97	4300319	VITE TCEI M8x25 UNI 5931 ZINC.	4 Socket head cup screw M8x25 ISO4762 Galvanized
1	98	3013011	PEDANA IN ALLUMINIO LATERALE (da matricola xxxxxx)	1 Side aluminium platform (from s/n xxxxxx)
1	99	3015096	PEDANA ALLUMINIO CENTRALE (da matricola xxxxxx)	1 Central aluminium platform (from s/n xxxxxx)
1	100	3015097	PEDANA ALLUMINIO DESTRA (da matricola xxxxxx)	1 Right aluminium platform (from s/n xxxxxx)
1	101	4300090	RIVETTO IN ALLUMINIO 3X8 (da matricola xxxxxx)	1 Rivet 3x8 (from s/n xxxxxx)

Part Nr refers always to one single parts



TAB.	POS.	Part Nr	DENOMINAZIONE	Q.ty	Description
2	1	2107783	ASTA DI SICUREZZA "C"	1	Safety rod
2	2	2107787	RISCONTRO ASTA DI SICUREZZA "C"	1	Safety rod feedback
2	3	2110729	BRACCIO CONTENITORE "C"	1	Hopper lifting arm
2	4	2111129	PARAURTI ANTERIORE	1	Front bumper
2	5	2111133	PROTEZIONE PARAURTO ANTERIORE	1	Front bumper protection
2	6	2111193	COFANO ANTERIORE COMPLETO	1	Front bonnet
2	7	2111198	CONTENITORE 160	1	Hopper
2	8	3000294	CAVO PER COFANO	2	Steel cable for bonnet
2	9	3001343	SUPPORTO PERNO RIBALTAMENTO	2	Pin tip support
2	10	3001748	FERMO PER COFANO	3	Stop for bonnet
2	11	3002271	RONDELLA DI SPESSORAMENTO Ø10.5 - Ø30 SP.5	2	Washer D.30x10x5
2	12	3007114	MOLLA FERMO ASTA	1	Safety rod spring
2	13	3007297	CERNIERA "STANLEY"	2	Hinge "Stanley"
2	14	3007789	SCIVOLO PER AGGANCIO ASTA	1	Safety rod housing
2	15	3010078	PIATTO CERNIERA COFANO ANTERIORE	2	Fixing plate for bonnet
2	16	3011686	RISCONTRO	1	Abutment
2	17	4300474	VITE TE M10X75 1/2 FILETTO ZINC. UNI 5737	1	Hexagon screw partially treaded M10x75 ISO 4014 Galvanized
2	18	3010355	TAPPO PER MANIGLIA	1	Cap for handle
2	19	3010762	PLASTICA PARAURTI ANTERIORE	1	Plastic front bumper
2	20	3011197	COPERTURA FANALI ANTERIORE	2	Front light closing
2	21	3011207	COPERCHIO CONTENITORE	1	Hopper cover
2	22	3011350	PROFILO MUSSE 5X20 CORTO	2	Gasket 5x20
2	23	4200227	CLACSON 12V	1	Klaxon 12 V
2	24	4200420	BOCCOLA GB 3030	2	Bush GB 3030
2	25	4200622	BUSSOLA K4 20 X 23 X 20	1	Socket K4 20x23x20
2	26	3011351	PROFILO MUSSE 5X20 LUNGO	2	Gasket 5x20
2	27	4200678	TIRANTE AGGANCIO COFANO	2	Tierod hooking bonnet
2	28	4200679	PIASTRINA DI ATTACCO E OCCHIELLO	2	Plate of attack and eyelet
2	29	4201289	TAMPONE IN GOMMA	2	Rubber buffer
2	30	4201358	CERNIERA DIRAK FORATURA 30 X 55	2	Hinge 30x55
2	31	4201699	CHIODINO ZINCATO CON RONDELLA	2	Brad galvanized with washer
2	32	4201713	MOLLA A TAZZA D40X20,4X1 DIN2093	4	Spring washer D.40x20.4x1 DIN 2093
2	33	4201756	COPRITESTA TONDO IN ABS NERO 18 X 1	1	Cap
2	34	4210313	MANIGLIA	1	Handle
2	35	4210314	CHIUSURA	1	Closure
2	36	4300029	DADO MEDIO M8 UNI 5588-6S ZINC.	2	Hexagon nut M8 ISO 4032/Galvanized
2	37	4300034	RONDELLA D.10,5 X 21 UNI 6592 ZINC.	16	Flat washer 10,5 x 21 ISO 7089 Galvanized
2	38	4300036	RONDELLA D.8,4 X 17 UNI 6592 ZINC.	4	Flat washer 8,4 x 17 ISO 7089 Galvanized
2	39	4300038	DADO AUTOFRENANTE M16 UNI7473	3	Hexagon self- locking nut M16 ISO 7040
2	40	4300039	RONDELLA D. 17X30 UNI 6592	5	Flat washer 17 x 30 ISO 7089 Galvanized
2	41	4300047	VITE TE M6X16 UNI5739 ZINC.	1	Hexagon screw M6x16 ISO 4017/Galvanized
2	42	4300048	RONDELLA D.6,4 X 12 UNI 6592 ZINC.	10	Flat washer 6,4 x 12 ISO 7089 Galvanized
2	43	4300049	RONDELLA D.4,3 X 9 UNI 6592 ZINC.	10	Flat washer 4,3 x 9 ISO 7089 Galvanized
2	44	4300050	VITE TE M6 X 20 UNI 5739 - 8.8 ZINC.	1	Hexagon screw M6x20 ISO 4017/Galvanized
2	45	4300051	DADO M6 AUTOFRENANTE UNI 7473 ZINC.	10	Hexagon self- locking nut M6 ISO 7040
2	46	3006921	PIASTRINA DI ATTACCO	2	Plate of attack
2	47	4300056	DADO M4 AUTOFRENANTE UNI 7473 ZINC.	20	Hexagon self- locking nut M4 ISO 7040
2	48	4300059	VITE TSPTC M4 X 10 UNI 7688-4 ZINC.	10	Screw M4x10 UNI 7688-4 Galvanized
2	49	4300079	DADO MEDIO M6 UNI 5588-6S ZINC.	11	Hexagon nut M6 ISO 4032/Galvanized
2	50	4300106	VITE TE M6 X 40 UNI 5739-8.8	1	Hexagon screw M6x40 ISO 4017/Galvanized
2	51	4300125	RONDELLA D.6,4 X 24 UNI 6593 ZINC.	1	Flat washer large series 6,4 x 24 ISO 7093 Galvanized
2	52	4300126	RONDELLA D.8 X 24 UNI 6593 ZINC.	10	Flat washer large series 8 x 24 ISO 7093 Galvanized
2	53	4300155	DADO IN GABBIA M6	4	Cage nut M6
2	54	4300158	VITE TBEI M4 X 12 UNI7380	10	Hexagon socket button cup screw M4x12 ISO 7380/Galvanized
2	55	4300162	VITE TE M16X50 ZINCATA	2	Hexagon screw M16x50 ISO 4017/Galvanized
2	56	4300173	VITE TBEI 6 X 20 ISO 7380 ZINC.	4	Hexagon socket button cup screw M6x20 ISO 7380/Galvanized
2	57	4300178	DADO MEDIO M10 UNI 5588 ZINC.	2	Hexagon nut M10 ISO 4032/Galvanized
2	58	4300188	VITE AUTOFILETTANTE 3,9 X 9,5	4	Self-tapping screw 3,9 x 9,5
2	59	4300204	VITE TE M10 X 30 UNI 5739 - 8.8 ZINC.	10	Hexagon screw M10x30 ISO 4017/Galvanized
2	60	4300222	VITE TBEI M8X20 UNI7380 ZINC.	6	Hexagon socket button cup screw M8x20 ISO 7380/Galvanized
2	61	4300224	RONDELLA D.6,4 X 18 UNI 6593 ZINC.	6	Flat washer large series 6,4 x 18 ISO 7093 Galvanized
2	62	4300237	VITE TBEI M10 X 20 ISO 7380	6	Hexagon socket button cup screw M10x20 ISO 7380/Galvanized
2	63	4300247	VITE TBEI M6 X 15 UNI 7380 ZINC.	3	Hexagon socket button cup screw M6x15 ISO 7380/Galvanized
2	64	4300346	VITE TE M8X16 UNI5739 ZINC.	10	Hexagon screw M8x16 ISO 4017/Galvanized
2	65	4300376	INSERTO FILETTATO M8 ZINCATO SEMIESAGONALE	6	Rivet M8
2	66	4300437	VITE TSPEI M6 X 20 UNI 5933 - 8.8 ZINC	8	Socket head flat countersunk M6x20 ISO 10642/Galvanized
		Part Nr	refers always to one single parts		

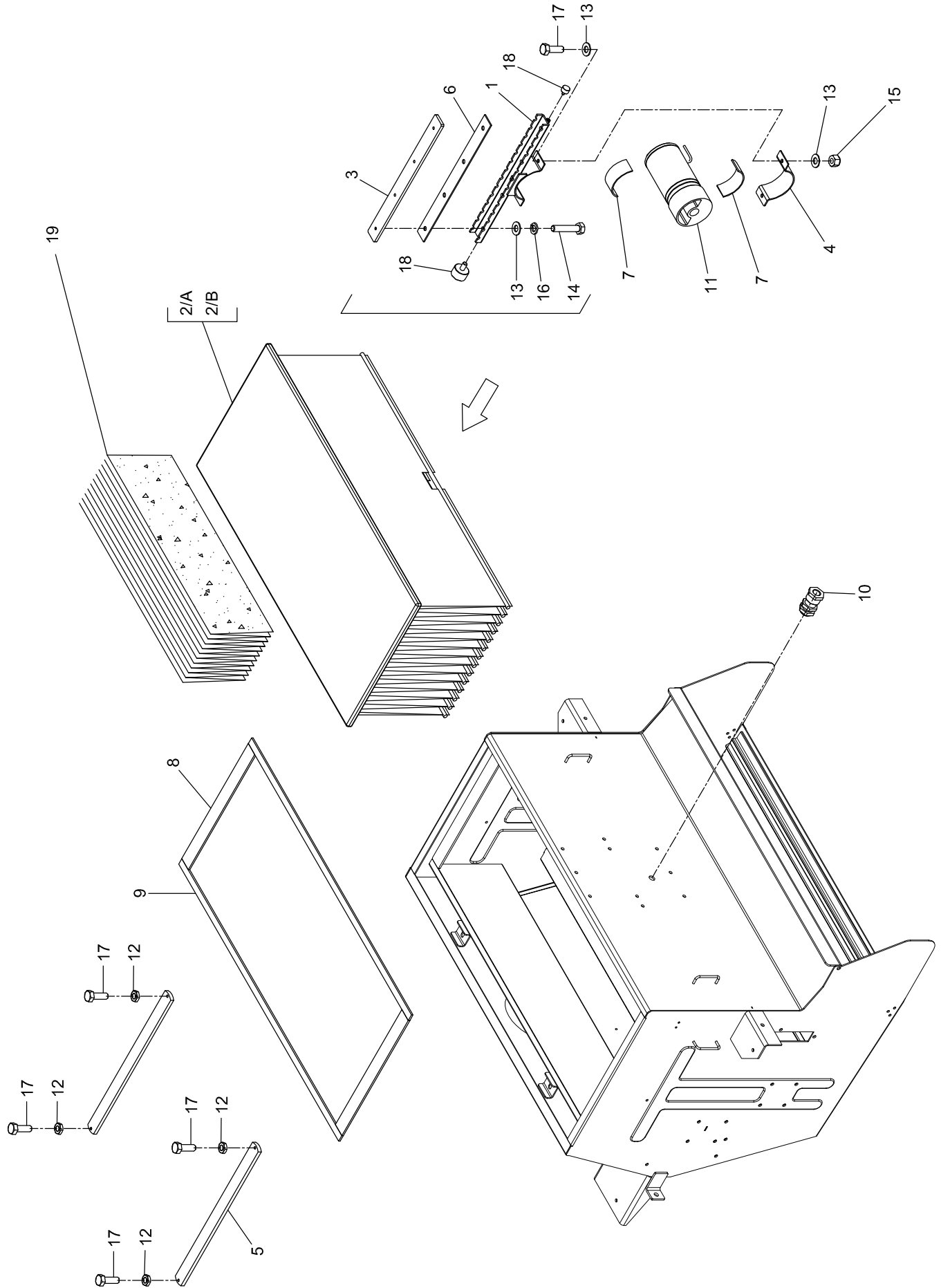



TAB.	POS.	Part Nr	DENOMINAZIONE	Q.ty	Description
3	1	2101731	SUPPORTO SCUOTIFILTRO	1	Filter shaker support
3	2A	2101928	GRUPPO FILTRANTE	1	Filtering
3	2B	2103946	GRUPPO FILTRANTE IN FELTRO	1	Felt filter
3	3	3001675	2° ELEMENTO SCUOTIFILTRO	1	Second element
3	4	3001730	COLLARE SUPPORTO SCUOTIFILTRO	1	Collar support filter shaker
3	5	3002129	FERMO PER FILTRO A SACCHE	2	Textile filter fastner
3	6	3002207	GUARNIZIONE PER SCUOTIFILTRO	1	Filter shaker gasket
3	7	3002760	GOMMA PER MOTORE SCUOTIFILTRO	2	Rubber for filter shaker motor
3	8	3008377	PROFILO MUSSE 40X5X413	2	Gasket 40x5x413
3	9	3008378	PROFILO MUSSE 20X5X993	2	Gasket 20x5x993
3	10	4200279	PRESSACAVO PG9	1	Cable holder PG9
3	11	4200638	SCUOTIFILTRO ELETTRICO 12V	1	Electric filter shaker 12V
3	12	4300012	DADO BASSO M8 UNI5589	4	Hexagon nut M8 ISO 4035/Galvanized
3	13	4300036	RONDELLA D.8,4 X 17 UNI 6592 ZINC.	8	Flat washer 8,4x17 ISO 7089 Galvanized
3	14	4300040	VITE TE M8 X 40 UNI 5739 - 8.8 ZINC.	4	Hexagon screw M8x40 ISO 4017/Galvanized
3	15	4300053	DADO M8 AUTOFRENANTE UNI 7473 ZINC.	2	Hexagon self-locking nut M8 ISO 7040
3	16	4300114	RONDELLA GROOVER D.8 UNI 1762 ZINC.	4	Split washer D.8 DIN 127/ Galvanized
3	17	4300293	VITE TE M8 X 25 UNI 5739 ZINC.	6	Hexagon screw M8x25 ISO 4017/Galvanized
3	18	6252624	ANTIVIBRANTE CIL. Ø20 M6	2	Anti vibration M6
3	19	2108384	KIT SEPARATORI FILTRO A SACCHE	1	Separators filter kit
		Part Nr	refers always to one single parts		

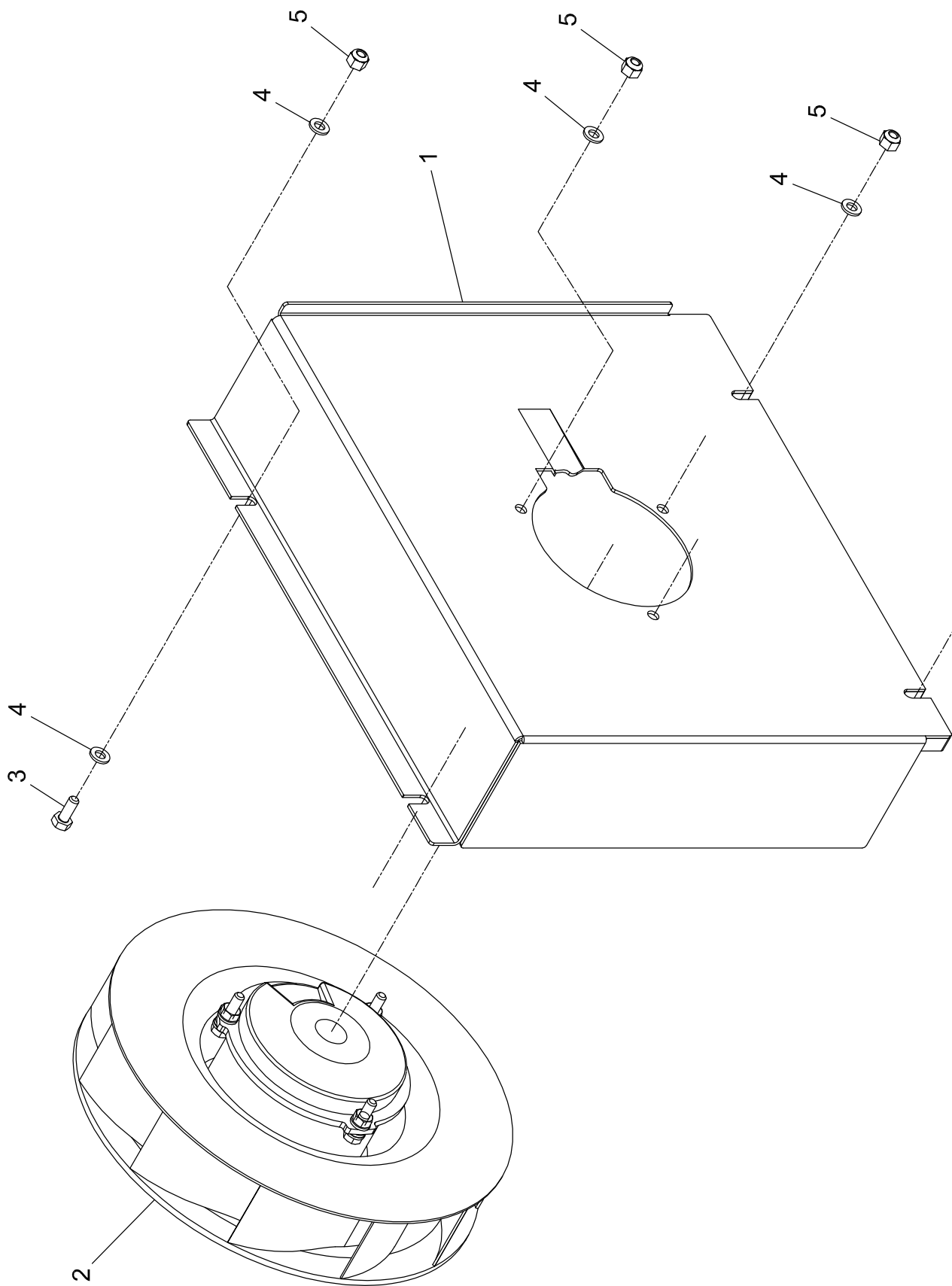

TAB.	POS.	Part Nr	DENOMINAZIONE	Q.ty	Description
4	1	2108410	SUPPORTO ELETTOVENTOLA	1	Electric fan support
4	2	4201254	MOTORE VENTOLA 12 VOLT	1	Electric fan motor 12V
4	3	4300047	VITE TE M6X16 UNI5739 ZINC.	2	Hexagon screw M6x16 ISO 4017/Galvanized
4	4	4300048	RONDELLA D.6,4 X 12 UNI 6592 ZINC.	9	Flat washer 6,4 x 12 ISO 7089 Galvanized
4	5	4300051	DADO M6 AUTOFRENANTE UNI 7473 ZINC.	7	Hexagon self- locking nut M6 ISO 7040
		Part Nr	refers always to one single parts		

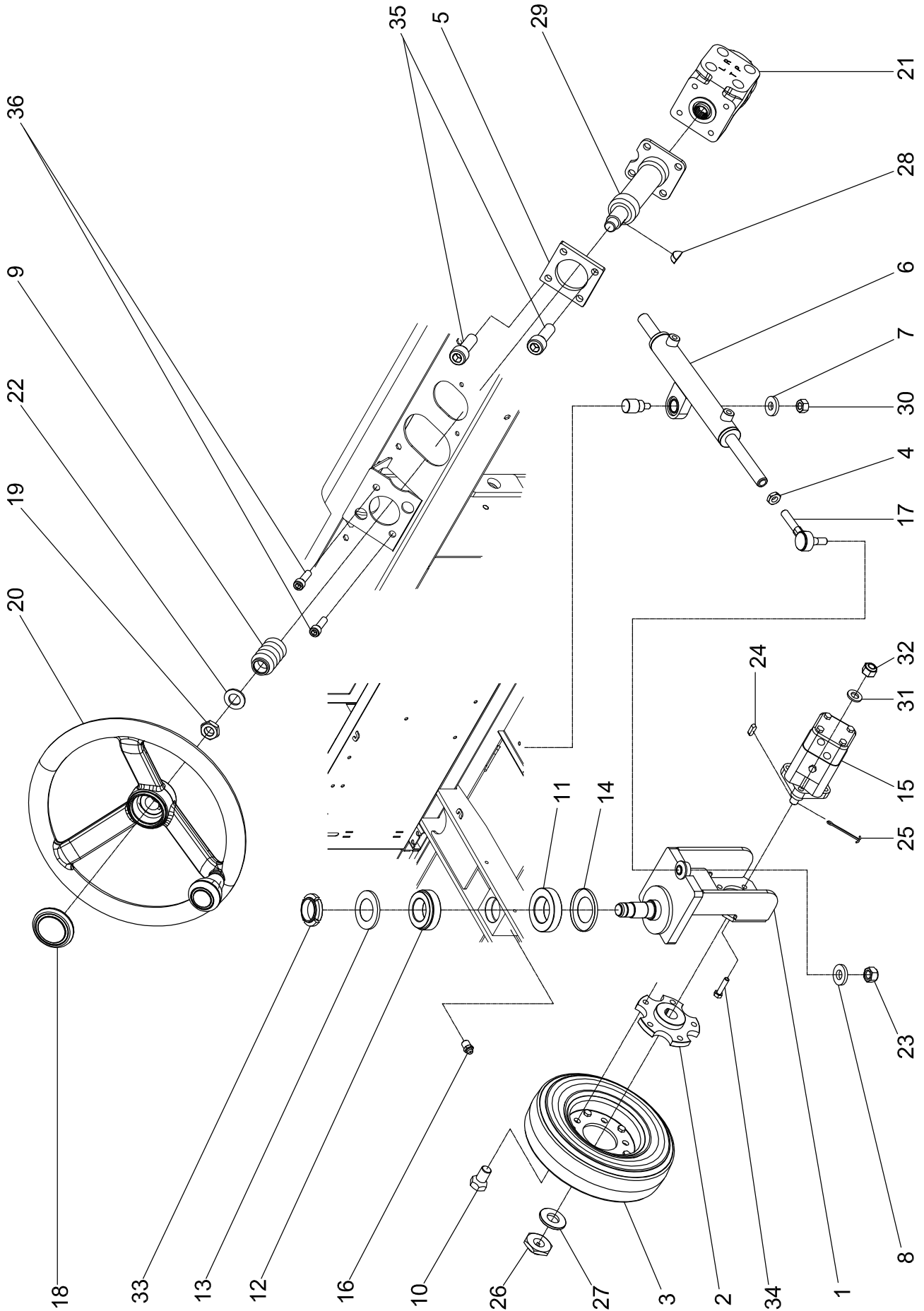

TAB.	POS.	Part Nr	DENOMINAZIONE	Q.ty	Description
5	1	2102630	SUPPORTO RUOTA POSTERIORE	1	Motor wheel hub support
5	2	3001330	MOZZO RUOTA	1	Wheel hub
5	3	3002181	RUOTA SUPERELASTICA 15-4 1\2-8	1	Wheel
5	4	3002678	CONTRODADO M16 X 1	1	Nut M16 x 1
5	5	3002686	DISTANZIALE PER IDROGUIDA	1	Spacer
5	6	3002708	CILINDRO IDROGUIDA	1	Power steering cylinder
5	7	3003639	RONDELLA D. 30 X 12,5 X 5 ZINC.	1	Washer D.30x12,5x5
5	8	3007917	RONDELLA D32X15X5	1	Washer for steering head
5	9	3008688	SOFFIETTO PER STERZO KM130/300	1	Bellows for steering
5	10	4200402	COLONNETTA DI SERRAGGIO RUOTE	5	Fixing screw M16x1,5
5	11	4200414	CUSCINETTO A RULLI CONICI / 32008	1	Tapered roller bearing 32008
5	12	4200415	CUSCINETTO A RULLI CONICI / 32007	1	Tapered roller bearing 32007
5	13	4200417	ANELLO NILOS 32007 AV	1	Rotary shaft seal 32007 AV
5	14	4200418	ANELLO NILOS 32008 AV	1	Rotary shaft seal 32008 AV
5	15	4200631	MOTORE IDRAULICO OMS 250	1	Hydraulic motor OMS 250
5	16	4200687	INGRASSATORE M8X1.25	1	Greaser M8 x 1,25
5	17	4200785	TESTINA PER CILINDRO	1	Steering head
5	18	4200815	TAPPO PER VOLANTE	1	Steering wheel cup
5	19	4200817	DADO PER VOLANTE	1	Nut for steering head
5	20	4200820	VOLANTINO D.350	1	Steering Wheel D.350
5	21	4200830	IDROGUIDA OSPC 50	1	Power steering OSPC 50 cc
5	22	4200907	RONDELLA PER VOLANTE	1	Steering wheel washer
5	23	4200908	DADO PER TESTINA	1	Nut for steering head
5	24	4200923	LINGUETTA A6X6X20 UNI 6604 / 69	1	Key hydraulic motor 6x6x20 ISO 773 B
5	25	4200924	COPPIGLIA D.3X40	1	Cotter pin D.3x40
5	26	4200925	DADO M20 X 1,5 CHIAVE 41	1	Nut for motor
5	27	4200926	RONDELLA D.44X20.5X4	1	Washer D.44X20.5X4
5	28	4200943	LINGUETTA A DISCO 5 X 6.5 UNI 6606	1	Key disc 5x6,5 ISO 3912
5	29	4201092	COLONNETTA STERZO H=150	1	Steering stud bolt H=150
5	30	4300057	DADO M12 UNI 5588	1	Hexagon nut M12 ISO 4032/Galvanized
5	31	4300058	RONDELLA 13 X 24 UNI6592 ZINC.	4	Flat washer D 13x24 ISO 7089 Galvanized
5	32	4300112	DADO AUTOBLOCCANTE M12	4	Hexagon self-locking nut M12 ISO 7040 Galvanized
5	33	4300163	GHIERA BLOCK M35X1.5	1	Self locking ring M35x 1,5
5	34	4300207	VITE TE M12 X 50 UNI 5739 - 8	4	Hexagon screw partially treaded M12x50 ISO 4014 Galvanized
5	35	4300248	VITE TCEI M10X30 UNI5931	2	Socket head cup screw M10x30 ISO4762 Galvanized
5	36	4300328	VITE TCEI M10 X 35 UNI 5931 - 8.8 ZINC.	2	Socket head cup screw M10x35 ISO4762 Galvanized
		Part Nr	refers always to one single parts		

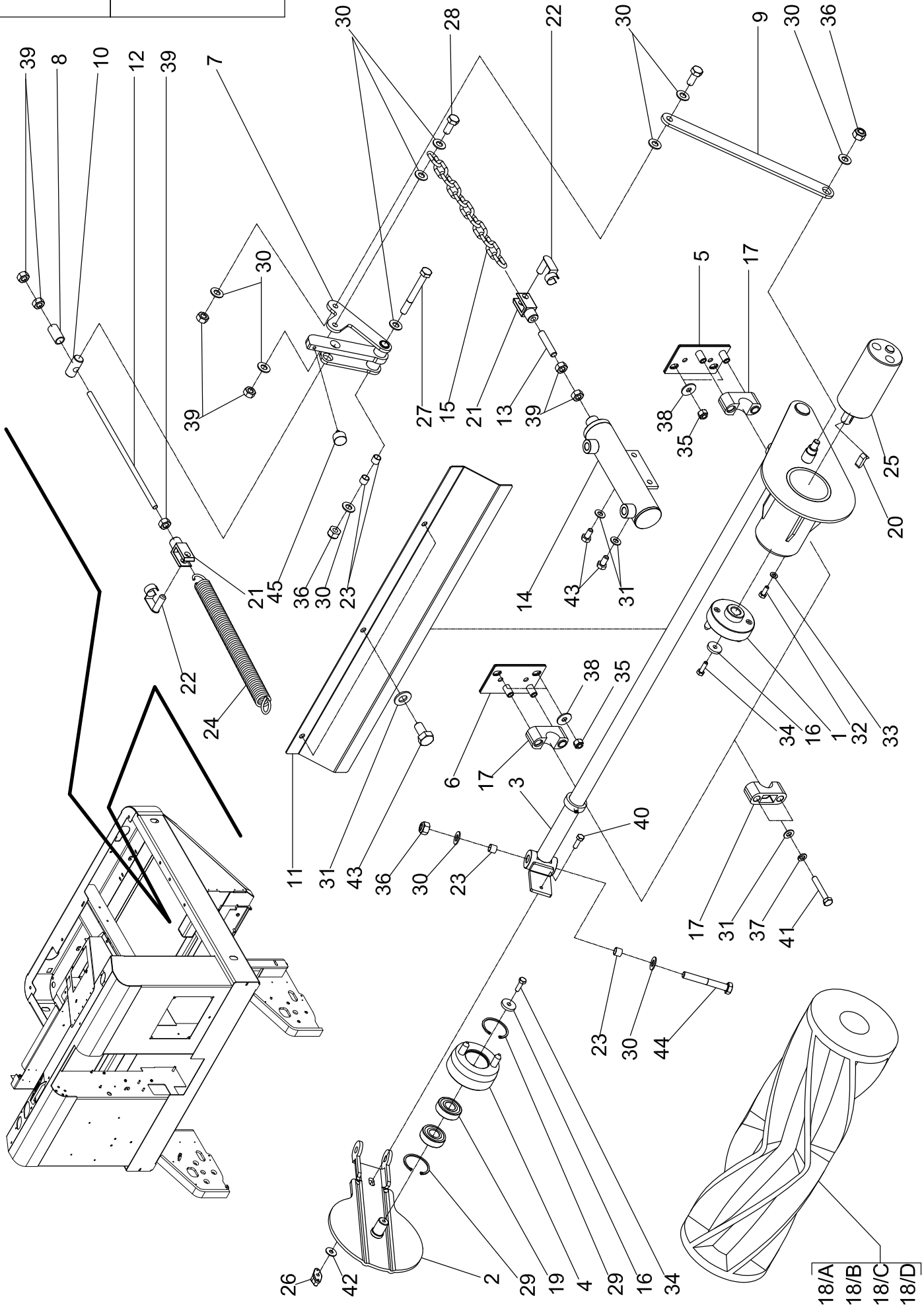

TAB.	POS.	Part Nr	DENOMINAZIONE	Q.ty	Description
6	1	2101359	MOZZO DI TRASCINAMENTO "C"	1	Drive hub
6	2	2102221	BRACCIO MOBILE SPAZZ.CENTRALE	1	Movable arm for main broom
6	3	2103309	ALBERO SUPP.SPAZZ.CENTRALE	1	Broom support shaft
6	4	2103312	MOZZO FOLLE	1	Idle hub
6	5	2103350	SUPPORTO CAVALLOTTO SX	1	Left support
6	6	2103351	SUPPORTO CAVALLOTTO DX	1	Right support
6	7	2108442	LEVA DI RINVIO SPAZZOLA CENT.	1	Main broom idle lever
6	8	3000937	DISTANZIALE	1	Spacer
6	9	3001724	ASTA SOLL. SPAZZOLA CENTRALE	1	Main broom lifting
6	10	3001728	PERNO PER LEVA DI RINVIO	1	Lever pin
6	11	3001858	PROTEZIONE PERNO SPAZZ.CENT.	1	Main broom shaft protection
6	12	3009453	TIRANTE SPAZZOLA CENTRALE	1	Rod
6	13	3002133	TIRANTE CILINDRO SPAZZOLA	1	Main broom cylinder rod
6	14	3002233	CILINDRO SPAZZOLE	1	Main broom cylinder
6	15	3002740	CATENA GENOVESE PER SPAZZOLA CENTRALE	1	Chain L.280 mm
6	16	3003221	RONDELLA D.23.5X6.5 ZINCATA	2	Washer D.6,5x23,5x4 Galvanized
6	17	3004207	CAVALLOTTO D.25.5	4	Staple D.25,5
6	18A	3007760	SPAZZOLA CENTRALE DOPPIA SETOLA PP 2,5X1,5	1	Main broom double bristle PP 2,5x1,5
6	18B	3003262	SPAZZOLA CENTRALE PP 1,0	1	Main broom PP 1,0
6	18C	3003526	SPAZZOLA CENTRALE PPL/ACCIAIO	1	Main broom PPL/Steel
6	18D	3003527	SPAZZOLA CENTRALE UNION MIX	1	Main broom "Union Mix"
6	19	4200005	CUSCINETTO 6203 2 RS	2	Bearing SKF 6203 2RS D.40x17
6	20	4200104	LINGUETTA A5X5X15 UNI 6604	1	Key 5x15
6	21	4200193	FORCELLA M10 ART.4514	2	Fork M10
6	22	4200194	SERRAGGIO AUT.X FORC.M10 ART. 4522	2	Fork locking M10
6	23	4200618	BUSSOLA K4 10X12X10	4	Bush K4 10x12x10
6	24	4200619	MOLLA A TRAZIONE	1	Spring D.3,2
6	25	4201064	MOTORE IDRAULICO 40CC	1	Hydraulic motor 40CC
6	26	4201782	POMELLO M6 ROSSO	1	Red knob M6
6	27	4300006	VITE TE M10 X 85 1/2 FIL. UNI 5737 ZINC.	1	Hexagon screw partially treaded M10x85 ISO 4014 Galvanized
6	28	4300007	VITE TE M10 X 25 UNI 5739 - 8.8 ZINC.	2	Hexagon screw M10X25 ISO 4017/Galvanized
6	29	4300031	SEEGER INTERNO D.40	2	Seeger ring D.40 DIN 471
6	30	4300034	RONDELLA D.10,5 X 21 UNI 6592 ZINC.	11	Flat washer D 10,5x21 ISO 7089 Galvanized
6	31	4300036	RONDELLA D.8,4 X 17 UNI 6592 ZINC.	9	Flat washer D 8,4x17 ISO 7089 Galvanized
6	32	4300047	VITE TE M6X16 UNI5739 ZINC.	3	Hexagon screw M6x16 ISO 4017/Galvanized
6	33	4300048	RONDELLA D.6,4 X 12 UNI 6592 ZINC.	3	Flat washer D 6,4x12 ISO 7089 Galvanized
6	34	4300050	VITE TE M6 X 20 UNI 5739 - 8.8 ZINC.	2	Hexagon screw M6x20 ISO 4017/Galvanized
6	35	4300053	DADO M8 AUTOFRENANTE UNI 7473 ZINC.	4	Hexagon self- locking nut M8 ISO 7040
6	36	4300070	DADO M10 AUTOFRENANTE UNI 7473-6S ZINC.	3	Hexagon self- locking nut M10 ISO 7040
6	37	4300114	RONDELLA GROOVER D.8 UNI 1762 ZINC.	4	Split washer D.8 DIN 127/ Galvanized
6	38	4300126	RONDELLA D.8 X 24 UNI 6593 ZINC.	4	Flat washer large series D.8x24 ISO 7093 Galvanized
6	39	4300178	DADO MEDIO M10 UNI 5588 ZINC.	7	Hexagon nut M10 ISO 4032/Galvanized
6	40	4300206	VITE TESTA ESAGONALE M6X20 INOX	1	Hexagon screw M6x20 ISO 4017 stainless steel
6	41	4300213	VITE TE M8X50 UNI 5739	4	Hexagon screw M8x50 ISO 4017/Galvanized
6	42	4300224	RONDELLA D.6,4 X 18 UNI 6593 ZINC.	1	Flat washer large series D.6,4x18 ISO 7093 Galvanized
6	43	4300346	VITE TE M8X16 UNI5739 ZINC.	5	Hexagon screw M8x16 ISO 4017/Galvanized
6	44	4300474	VITE TE M10X75 1/2 FILETTO ZINC. UNI 5737	1	Hexagon screw partially treaded M10x 75 ISO 4014 Galvanized
6	45	6252624	ANTIVIBRANTE CIL. Ø20 M6	1	Anti vibration M6
6					
		Part Nr	refers always to one single parts		

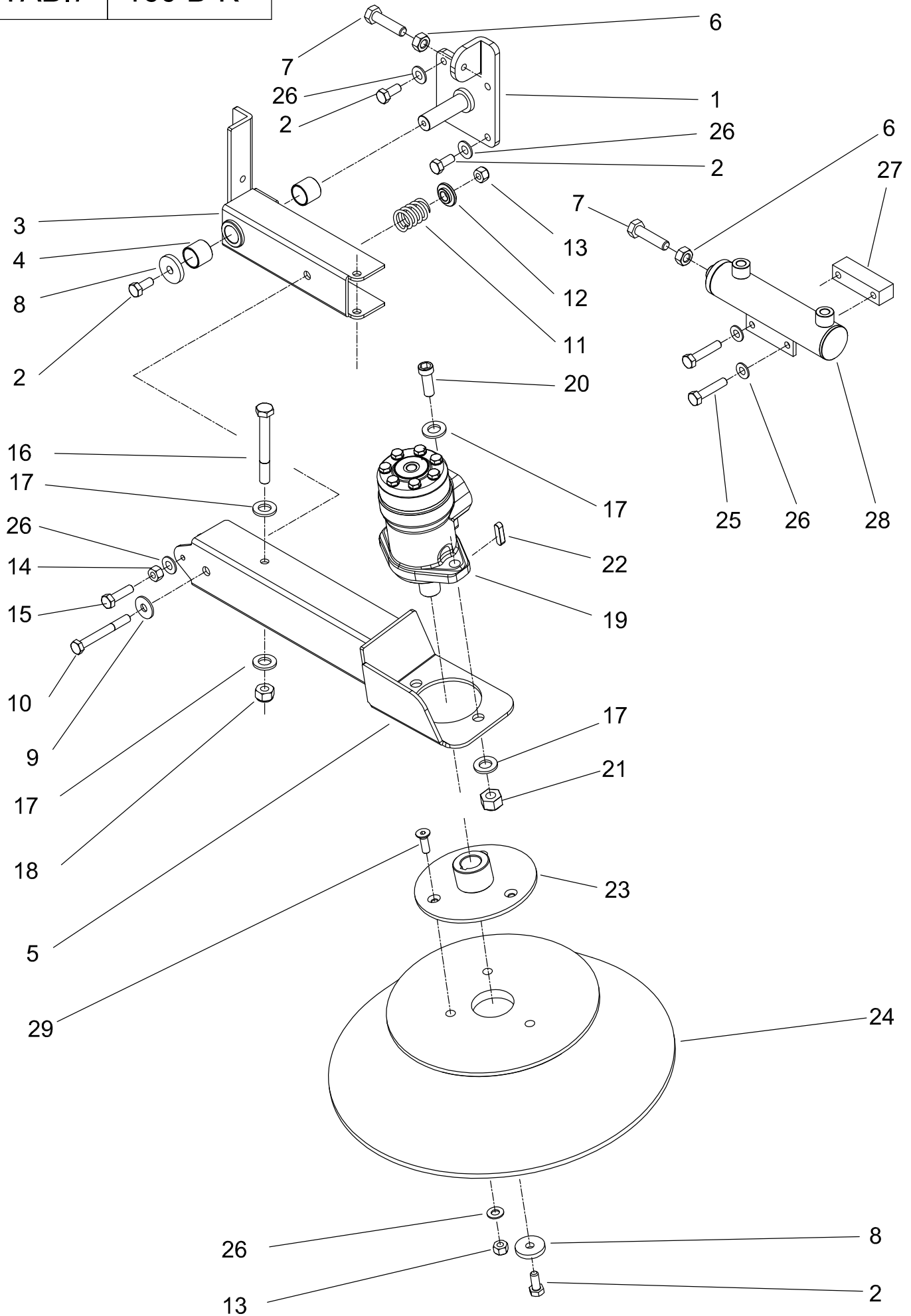



TAB.	Pos.	Part Nr	DENOMINAZIONE	Q.ty	Description
7	1	2101630	SUPPORTO SPAZZOLA DESTRA	1	Right broom support
7	2	4300033	VITE TE M8X20 UNI 5739-8.8 / ZINC	6	Hexagon screw M8x20 ISO 4017/Galvanized
7	3	2101498	BRACCIO SPAZZOLA LATERALE DESTRO	1	Right side broom arm
7	4	4200622	BUSSOLA K4 10 X 12 X 10	2	Socket K4 10 x 12 x 10
7	5	2103314	BRACCIO SPAZZOLA DESTRO	1	Side broom arm
7	6	4300178	DADO ESAG. MEDIO M10 UNI 5588 / ZINC.	2	Hexagon nut M10 ISO 4032/Galvanized
7	7	4300227	VITE TE M10 X 40 UNI 5739-8.8 / ZINC.	1	Hexagon screw M10x40 ISO 4017/Galvanized
7	8	3000098	RONDELLA PER ALBERO DI COMANDO	1	Washer for drive shaft
7	9	4300126	RONDELLA D.8 X 24 UNI 6593/ ZINC.	1	Flat washer large series D.8x24 ISO 7093 Galvanized
7	10	4300061	VITE TE M8X60 UNI 5739-8.8 / ZINC.	1	Hexagon screw M8x60 ISO 4017/Galvanized
7	11	4200693	MOLLA RIENTRO SPAZZOLA	1	Spring
7	12	3001511	RONDELLA DI FERMO MOLLA	1	Spring stop washer
7	13	4300053	DADO M8 AUTOFREANANTE UNI 7473 ZINC	4	Hexagon self- locking nut M8 ISO 7040
7	14	4300029	DADO MEDIO M8 UNI 5588 ZINC.	1	Hexagon nut M8 ISO 4032 Galvanized
7	15	4300108	VITE TE M8X30 UNI 5739-8.8 / ZINC.	1	Hexagon screw M8x30 ISO 4017/Galvanized
7	16	4300006	VITE TE M10X85 UNI 5737-8.8 / ZINC	1	Hexagon screw M10x85 ISO 4017/Galvanized
7	17	4300058	RONDELLA D.13X 24 UNI 6592 / ZINC.	6	Flat washer D 13x24 ISO 7089 Galvanized
7	18	4300070	DADO AUTOBLOCCANTE M10	1	Hexagon self- locking nut M10 ISO 7040
7	19	4201065	MOTORE IDRAULICO OMP 200	1	Hydraulic motor OMP 200
7	20	4300209	VITE TCEI M12 X 40 UNI 5931-8.8 ZINC.	2	Socket head cup screw M12x40 ISO4762 Galvanized
7	21	4300112	DADO AUTOFREANANTE M12 UNI 7463-6S ZINC.	2	Hexagon self- locking nut M12 ISO 7040
7	22	4200922	LINGUETTA 8X7X32 UNI 6604-A	1	Key 8x7x32 ISO 773A
7	23	2101938	MOZZO SPAZZOLA LATERALE	1	Side broom hub
7	24	3007959	SPAZZOLA LATERALE	1	Side broom
7	25	4300288	VITE TE M8 X 55 UNI 5739-8.8 / ZINC.	2	Hexagon screw M8x55 ISO 4017/Galvanized
7	26	4300036	RONDELLA D. 8,4 x 17 UNI 6592 /ZINC	10	Flat washer D 8,4x17 ISO 7089 Galvanized
7	27	3001837	SUPPORTO PER CILINDRO	1	Cylinder support
7	28	3002233	CILINDRO SPAZZOLE	1	Main broom cylinder
7	29	4300289	VITE TSPEI M8X40 UNI 5933 /ZINC.	3	Socket head flat countersunk M8x40 ISO10642 Galvanized
		Part Nr	refers always to one single parts		

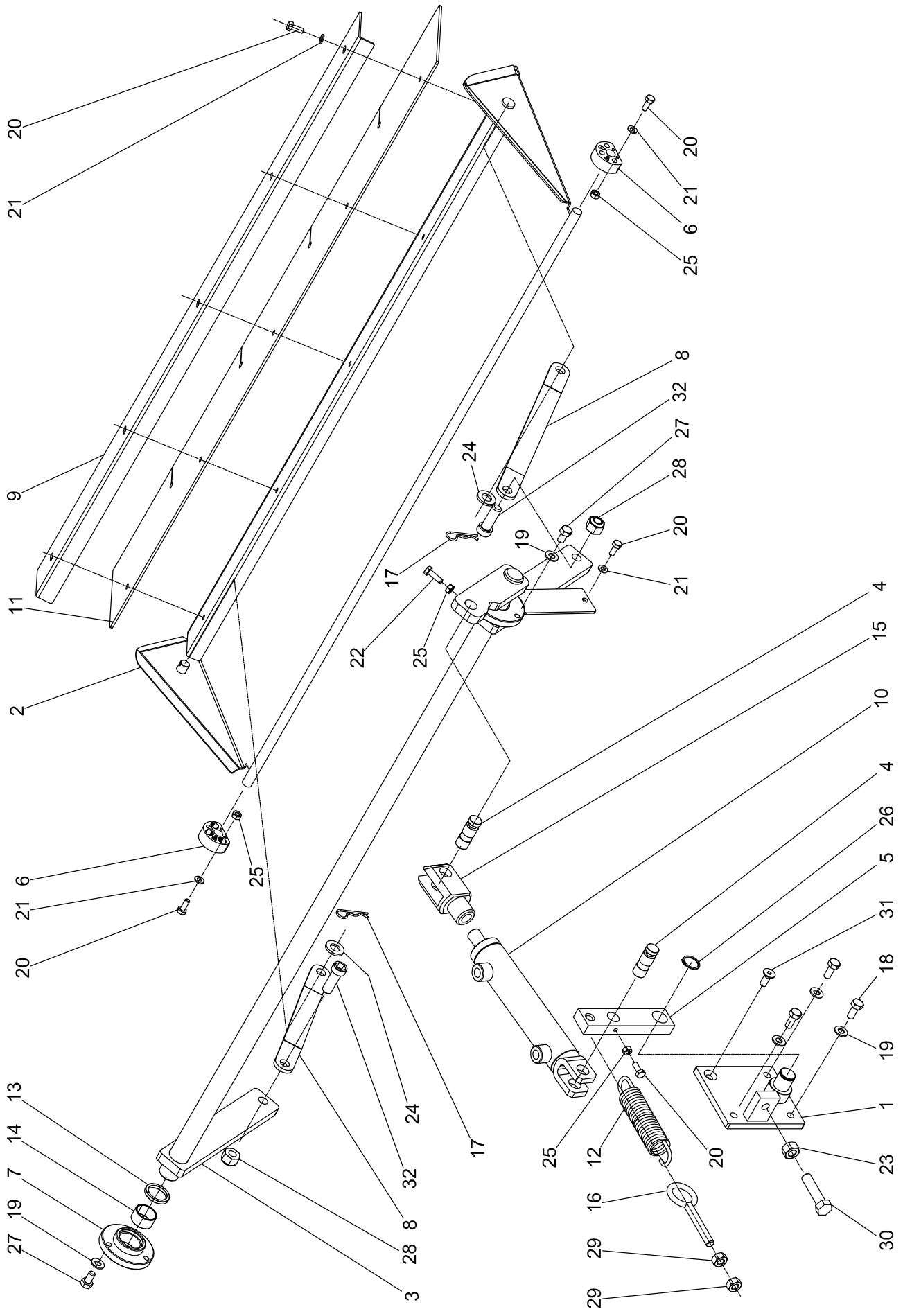

TAB.	POS.	Part Nr	DENOMINAZIONE	Q.ty	Description
8	1	2101722	PIASTRA CILINDRO FLAP	1	Flap cylinder plate with pin
8	2	2101880	FLAP "C"	1	Flap
8	3	2101889	ALBERO APERTURA FLAP	1	Shaft to open flap
8	4	3001189	PERNO CILINDRO FLAP	2	Flap cylinder pin
8	5	3001355	ATTACCO PISTONE FLAP	1	Flap piston attachment
8	6	3001360	CERNIERA FLAP	2	Hinge
8	7	3001645	SUPPORTO ALBERO FLAP SX	1	Left flap shaft support
8	8	3001711	ASTA CHIUSURA FLAP	2	Rod to command flap
8	9	3001878	FERMO GOMMA FLAP	1	Locking strip for flap
8	10	3002231	CILINDRO FLAP	1	Flap cylinder
8	11	3002259	FLAP CONTENITORE	1	Flap hopper
8	12	4200416	MOLLA A TRAZIONE	1	Spring D.28
8	13	4200419	ANELLO G25.32.4	1	Ring G25.32.4
8	14	4200421	BOCCOLA GB2515	1	Bush BG 2515
8	15	4200571	FORCELLA M16	1	Fork M16
8	16	4200632	OCCHIO FORGIATO M10	1	Grommet M10
8	17	4311220	COPPIGLIA A MOLLA D.2 L=50 DIN 11024 INOX	2	Retaining Pin d.2 L=50 DIN 11024 inox
8	18	4300033	VITE TE M8 X 20 UNI 5739 - 8.8 ZINC.	3	Hexagon screw M8x20 ISO 4017/Galvanized
8	19	4300036	RONDELLA D.8,4 X 17 UNI 6592 ZINC.	9	Flat washer D 8,4x17 ISO 7089 Galvanized
8	20	4300047	VITE TE M6X16 UNI5739 ZINC.	13	Hexagon screw M6x16 ISO 4017/Galvanized
8	21	4300048	RONDELLA D.6,4 X 12 UNI 6592 ZINC.	12	Flat washer 6,4 x 12 ISO 7089 Galvanized
8	22	4300050	VITE TE M6 X 20 UNI 5739 - 8.8 ZINC.	1	Hexagon screw M6x20 ISO 4017/Galvanized
8	23	4300057	DADO M12 UNI 5588	1	Hexagon nut M12 ISO 4032/Galvanized
8	24	4300058	RONDELLA 13 X 24 UNI6592 ZINC.	2	Flat washer13 x 24 ISO 7089 Galvanized
8	25	4300079	DADO MEDIO M6 UNI 5588-6S ZINC.	8	Hexagon nut M6 ISO 4032/Galvanized
8	26	4300103	SEEGER PER ALBERO Ø20 UNI7435	1	Seeger ring D.20 DIN 471
8	27	4300107	VITE TE M8X15 UNI5739 ZINC.	6	Hexagon screw M8x15 ISO 4017/Galvanized
8	28	4300112	DADO AUTOBLOCCANTE M12	2	Hexagon self- locking nut M12 ISO 7040 Galvanized
8	29	4300178	DADO MEDIO M10 UNI 5588 ZINC.	2	Hexagon nut M10 ISO 4032/Galvanized
8	30	4300207	VITE TE M12 X 50 UNI 5739 - 8	1	Hexagon screw M12x50 ISO 4017/Galvanized
8	31	4300210	VITE T.S.P.E.I. M8X20	1	Socket head flat countersunk M8x 20 ISO 10642/Galvanized
8	32	4300226	VITE TCEI M12 X 35 UNI 5931-8 / 8	2	Socket head cup screw M12x35 ISO4762 Galvanized
		Part Nr	refers always to one single parts		

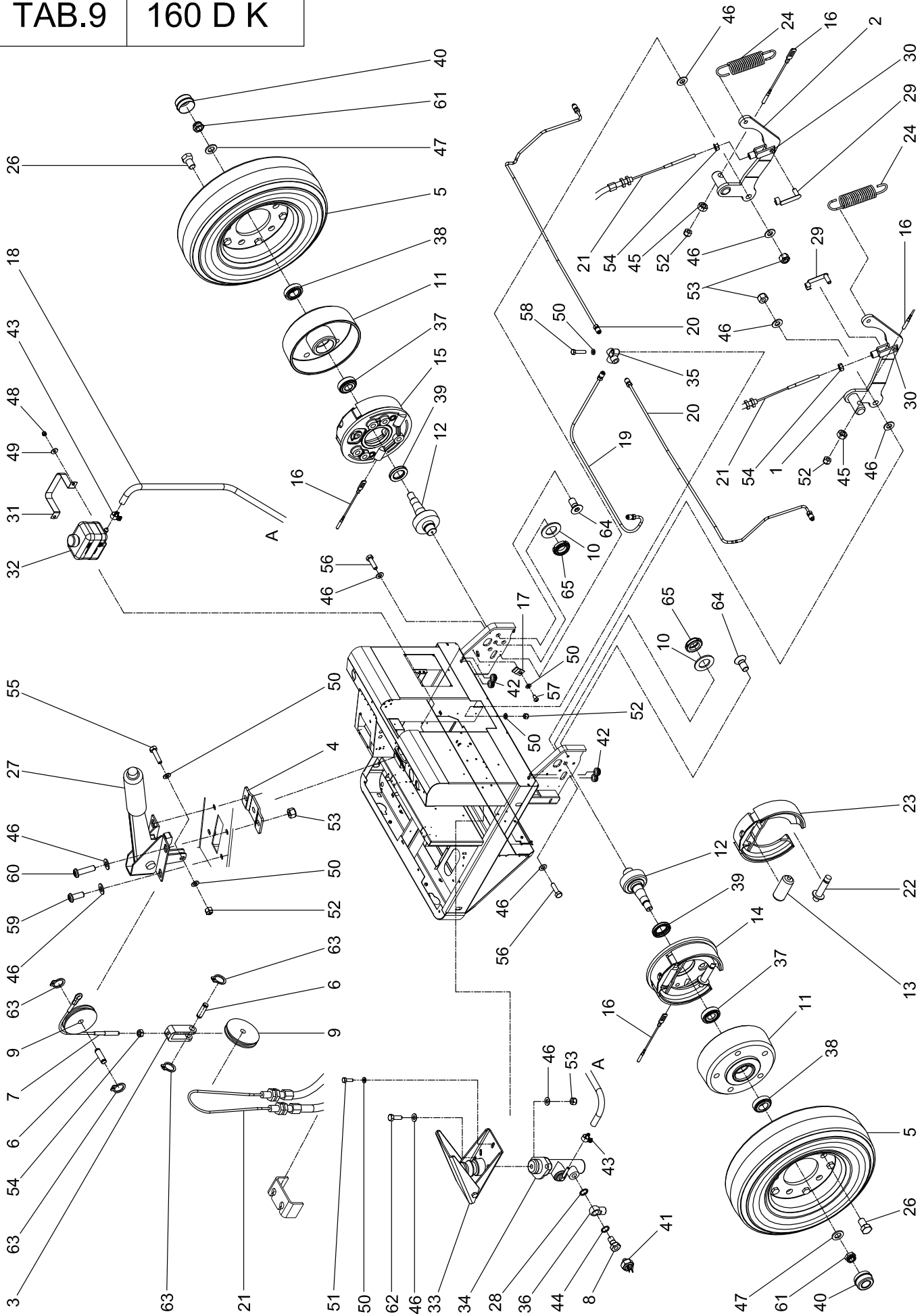

TAB.	POS.	Part Nr	DENOMINAZIONE	Q.ty	Description
9	1	2108127	LEVA FRENO DX	1	Right brake lever
9	2	2108129	LEVA FRENO SX	1	Left brake lever
9	3	3001656	FORCELLA SUPPORTO CARRUCOLA	1	Fork pulley support
9	4	3001912	FERMO	1	Brake lever stop
9	5	3002181	RUOTA SUPERELASTICA 15-4 1/2-8	2	Wheel
9	6	3002265	PERNO PER FORCELLA CARRUCOLA	2	Pulley fork pin
9	7	3002555	CAVETTO FRENO A MANO	1	Handbrake cable
9	8	3003922	RACCORDO FORATO M12X1.5	1	Union M12x1,5
9	9	3007060	CARRUCOLA FERRO	2	Pulley
9	10	3007375	RONDELLA	2	Washer
9	11	3007471	MOZZO FOLLE RUOTA ANTERIORE	2	Front wheel hub
9	12	3007667	PERNO SUPPORTO RUOTA ANTERIORE	2	Front wheel shaft
9	13	3007836	CILINDRETTO SPECIALE D.15,87	2	Brake cylinder D.15,87
9	14	3007837	MASSA FRENO 180°40 DX CON LEVA	1	Right brake plate
9	15	3007838	MASSA FRENO 180°40 SX CON LEVA	1	Left brake plate
9	16	3007844	CAVETTO PER MASSA FRENO	2	Brake cable
9	17	3008052	FERMO PER TUBO FRENO	2	Stop for copper pipe
9	18	3008365	TUBO OLIO IN GOMMA	1	Rubber hose
9	19	3008379	TUBO IN RAME 3X5 L.530	1	Copper pipe 3x5
9	20	3008380	TUBO IN RAME 3X5 L.760	2	Copper pipe 3x5
9	21	3008381	FUNE FRENO A MANO	1	Hand brake cable
9	22	3008395	REGISTRO MASSA FRENO CON LEVA	2	Adjustment brake lever
9	23	3008396	COPIA GANASCIE FRENO CON LEVA	2	Pair brake shoes with lever
9	24	3008424	MOLLA TRAZIONE TR46	2	Spring TR46
9	25	4000780	OLIO PER FRENI 0,25 L	1	Brake oil 0,25 L
9	26	4200402	COLONNETTA DI SERRAGGIO RUOTE	10	Fixing screw M16x1,5
9	27	4200642	LEVA FRENO	1	Brake lever
9	28	4200718	RONDELLA IN RAME 1/4"	1	Copper washer 1/4 "
9	29	4200754	CLIP LUNGA M6	2	Fork locking M6
9	30	4200755	FORCELLA LUNGA M6	2	Fork M6
9	31	4200783	STAFFA PER SERBATOIO	1	Bracket for tank
9	32	4200784	SERBATOIO OLIO FRENO	1	Tank for oil brake
9	33	4200787	PEDALE FRENO	1	Brake pedal
9	34	4200788	POMPA FRENO	1	Brake pump
9	35	4200789	RACCORDO OTT.3 VIE 10 X 1,25	1	Tree- way connector with connection stop
9	36	4200790	RACCORDO AD OCCHIO M10X1,25	1	Eye shaped union M10x1,25
9	37	4200876	CUSCINETTO CONICO 30204	2	Tapered roller bearing 30204
9	38	4200879	CUSCINETTO CONICO 32005	2	Tapered roller bearing 32005
9	39	4200880	PARAOLIO 30.47.7	2	Rotary shaft seal 30.47.7 ISO 6194
9	40	4200883	CALOTTINA COPRIMOZZO D.47	2	Cover hub bowl diam 47
9	41	4200886	PRESSOSTATO PER STOP	1	Stop pressure switch
9	42	4201757	PASSACAVO 18 X 16 X 3,5	4	Cable holder
9	43	4210747	FASCETTA A COLLARINO D.11-13	2	Hose clamp D.11-13
9	44	4211215	RONDELLA IN RAME D.18X14 SP.1,5	1	Copper washer D.18x14x1,5
9	45	4300029	DADO MEDIO M8 UNI 5588-6S ZINC.	2	Hexagon nut M8 ISO 4032/Galvanized
9	46	4300036	RONDELLA D.8,4 X 17 UNI 6592 ZINC.	14	Flat washer D 8,4x17 ISO 7089 Galvanized
9	47	4300039	RONDELLA D. 17X30 UNI 6592	2	Flat washer D.17x30 ISO 7089 Galvanized
9	48	4300041	DADO M5 AUTOFRENANTE UNI 7473-6S ZINC.	2	Hexagon self- locking nut M5 ISO 7040
9	49	4300045	RONDELLA D.5,5 X 15 UNI 6593 ZINC.	2	Flat washer large series D.5,5x15 ISO 7093 Galvanized
9	50	4300048	RONDELLA D.6,4 X 12 UNI 6592 ZINC.	12	Flat washer D 6,4x12 ISO 7089 Galvanized
9	51	4300050	VITE TE M6 X 20 UNI 5739 - 8.8 ZINC.	3	Hexagon screw M6x20 ISO 4017/Galvanized
9	52	4300051	DADO M6 AUTOFRENANTE UNI 7473 ZINC.	7	Hexagon self- locking nut M6 ISO 7040
9	53	4300053	DADO M8 AUTOFRENANTE UNI 7473 ZINC.	6	Hexagon self- locking nut M8 ISO 7040
9	54	4300079	DADO MEDIO M6 UNI 5588-6S ZINC.	3	Hexagon nut M6 ISO 4032/Galvanized
9	55	4300087	VITE TE M6X25 ZINC.	1	Hexagon screw M6x25 ISO 4017/Galvanized
9	56	4300108	VITE TE M8 X 30 UNI 5739 ZINC.	2	Hexagon screw M8x30 ISO 4017/Galvanized
9	57	4300148	VITE TBEI M6 X 10 UNI 7380 ZINC.	2	Screw TBEI M6 X 10 ISO 7380/Galvanized
9	58	4300185	VITE TESTA ESAGONALE M6X30 ZINCATA	1	Hexagon screw M6x30 ISO 4017/Galvanized
9	59	4300222	VITE TBEI M8X20 UNI7380 ZINC.	2	Screw TBEI M8 X 20 ISO 7380/Galvanized
9	60	4300232	VITE TBEI M8X30 ZINCATA	2	Screw TBEI M8 X 30 ISO 7380/Galvanized
9	61	4300244	DADO AUTO. M16X1,5 UNI 10331	2	Self locking nut M16x1,5
9	62	4300293	VITE TE M8 X 25 UNI 5739 ZINC.	2	Hexagon screw M8x25 ISO 4017/Galvanized
9	63	4300327	SEEGER PER ALBERO D.8 UNI7435	4	Seeger ring D.8 DIN 6799
9	64	4300446	VITE TSPEI M14X30 UNI5933	6	Socket head flat countersunk M14x30 ISO 10642/Galvanized
9	65	4300447	GHIERA M25 X 1,5	2	Self locking ring M25x1,5
		Part Nr	refers always to one single parts		

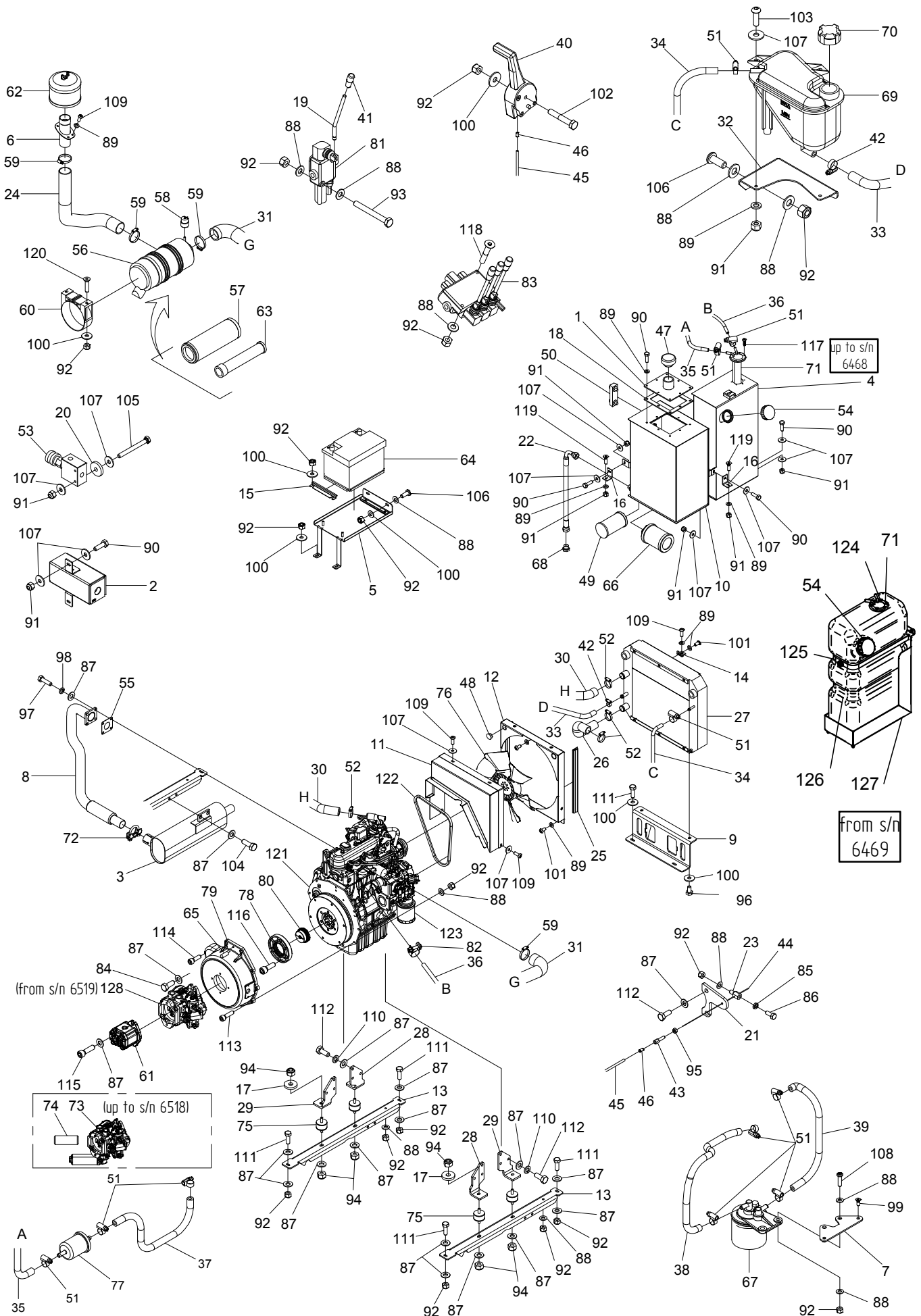

TAB.	POS.	Part Nr	DENOMINAZIONE	Q.ty	Description
10	1	2102286	COPERCHIO SERBATOIO	1	Cover
10	2	2106944	RACCOGLITORE OLIO "C"	1	Oil collector
10	3	2107698	SILENZIATORE KM130/300 GPL	1	Exhaust dumper
10	4	2108285	SERBATOIO GASOLIO (fino a mat.6468)	1	Fuel tank (up to s/n 6468)
10	5	2108292	SUPPORTO BATTERIA	1	Battery support
10	6	2108351	TUBO DI ASPIRAZIONE VERTICALE "C"	1	Suction pipe
10	7	2109915	SUPPORTO FILTRO NAFTA	1	Support fuel filter
10	8	2110789	MARMITTA 160 DK	1	Exhaust160 DK
10	9	2110792	SUPPORTO RADIATORE	1	Radiator support
10	10	2110812	SERBATOIO OLIO	1	Oil tank
10	11	2111091	RIPARO VENTOLA	1	Fan guard
10	12	3011028	CONVOGLIATORE VENTOLA	1	Fan conveyor
10	13	2111219	STAFFA SUPPORTO MOTORE	2	Engine support bracket
10	14	3011239	FERMO RADIATORE	1	Latch plate heat exchanger
10	15	3001365	ANGOLARE STRINGIBATTERIA	1	Battery holder
10	16	3001650	PIASTRINA FISS.SERBATOIO OLIO	2	Oil tank locking plate
10	17	3002271	RONDELLA DI SPESSORAMENTO Ø10.5 - Ø30 SP.5	4	Washer D.30x10,5x5
10	18	3002657	GUARNIZIONE COPERCHIO	1	Gasket
10	19	3002692	LEVA DISTRIBUTORE	1	Leverage distributor
10	20	3003221	RONDELLA D.23.5X6.5 ZINCATA	2	Washer D.6,5x23,5x4
10	21	3006249	PIATTO GUIDA FILO GAS	1	Flat wire gas
10	22	3007860	TUBO SCARICO OLIO SERBATOIO	1	Oil tank drain hose
10	23	3007912	FERMO CAVO ACCELERATORE	1	Throttle cable retainer
10	24	3008401	TUBO ASPIRAZIONE PREFILTRO	1	Suction hose filter from cyclon to filter
10	25	3009053	GUARNIZIONE TRAFILATA ARMATA L.350MM	2	Gasket L.350
10	26	3009908	TUBO ACQUA INFERIORE	1	Lower water pipe
10	27	3010756	RADIATORE COMBINATO ACQUA-OLIO	1	Radiator
10	28	3010784	STAFFA MOTORE	2	Engine support bracket
10	29	3010785	STAFFA MOTORE	2	Engine support bracket
10	30	3010809	TUBO ACQUA SUPERIORE	1	Upper water pipe
10	31	3011035	TUBO ASPIRAZIONE FILTRO	1	Suction hose filter
10	32	3011216	STAFFA SUPP. VASCHETTA ACQUA	1	Water tank bracket
10	33	3011237	TUBO MANDATA ACQUA	1	Water delivery pipe
10	34	3011238	TUBO RITORNO ACQUA	1	Water return pipe
10	35	3011241	TUBO MANDATA CARBURANTE	1	Fuel delivery pipe
10	36	3011242	TUBO RITORNO CARBURANTE	1	Fuel return pipe
10	37	3011243	TUBO CARBURANTE L.500	1	Fuel tube L.500mm
10	38	3011244	TUBO CARBURANTE L.350	1	Fuel tube L.350mm
10	39	3011245	TUBO CARBURANTE L.250	1	Fuel tube L.250mm
10	40	3011251	LEVA ACCELERATORE FORATA	1	Throttle lever
10	41	4200019	POMELLO "ELESA" PL 30 M8	1	Knob ELESA PL 30 M8
10	42	4200170	FASCETTA STRINGITUBO 16-25	2	Hose clamp D.16-25
10	43	4200209	REGISTRO FILO M6	1	Adjustment M6
10	44	4200271	FILO ACCELERATORE D 1,6	1	Accelerator cable
10	45	4200272	GUAINA D.5	1	Sheating D.5
10	46	4200273	TERMINALE PER GUAINA D. 5	2	Terminal sleeve D.5
10	47	4200508	TAPPO SERBATOIO OLIO CON SFIATO 1" 1/4	1	Air hole cup 1" 1/4"
10	48	4200581	TAPPO	2	Plug
10	49	4200614	FILTRO OLIO DA 1"-25M IN CARTA	1	Suction oli filter 1"-25 micron
10	50	4200615	INDICATORE OTTICO DI LIVELLO	1	Level indicator
10	51	4200691	FASCETTA STRINGITUBO 10-16	11	Hose clamp D.10-16
10	52	4200692	FASCETTA STRINGITUBO 25-40	4	Hose clamp D.25-40
10	53	4200813	VALVOLA PRIORITARIA 3/8"	1	Priority valve 3/8"
10	54	4200877	TAPPO SERBATOIO GASOLIO	1	Fuel tank cap
10	55	4200889	GUARNIZIONE MARMITTA	1	Exhaust gasket
10	56	4200892	FILTRO ARIA 5" COMPLETO	1	Air filter 5"
10	57	4200893	CARTUCCIA FILTRO ARIA	1	Air filter cartridge
10	58	4200894	PRESSOSTATO FILTRO INTASATO	1	Pressure switch block up filter
10	59	4200896	FASCETTA STRINGITUBO 40-60	4	Hose clamp D.40-60
10	60	4200904	FASCETTA FISSAGGIO FILTRO	1	Filter locking strip
10	61	4200945	POMPA INGR. 8,5CC	1	Gear pump 8,5 cc COD. HPLPA208DSVG4G4BST
10	62	4200954	PREFILTRO A CICLONE	1	Cyclon air prefilter
10	63	4200994	CARTUCCIA DI SICUREZZA	1	Safety cartridge
10	64	4201032	BATTERIA 12V - 60AH	1	Battery 12V- 60 A/h
10	65	4201228	SPINA CILINDRICA H6 8X20	1	Cylindrical pin H6 8 X 20
10	66	4201277	FILTRO 10M IN CARTA POMPA PORT. VAR.PB155	1	Filter element
10	67	4201628	FILTRO GASOLIO KUBOTA V 1505	1	Fuel filter
10	68	4201716	TAPPO 1/2" M (BSP 60°)	1	Cap 1/2" M ( BSP 60°)
10	69	4201749	VASCHETTA RECUPER ACQUA CON TAPPO	1	Recovery tank
10	70	4201750	TAPPO VASCHETTA	1	Tank cap
10	71	4201768	INDICATORE LIVELLO GASOLIO	1	Fuel level indicator
10	72	4201771	CAVALLOTTO 10.017.43	1	Staple 10.017.43
10	73	4201777	POMPA PORTATA VARIABILE (fino a mat.6518)	1	Hydraulic variable pump COD.ZSMPZ14RSVGKEA2V70 (up to s/n6518)
10	74	4201778	FILTRO PER POMPA PV (fino a mat.6518)	1	Pump filter (up to s/n6518)
10	75	4201831	SILENT BLOCK 50X30 M10 X 25 70SH	4	Silent block
10	76	4201987	KIT VENTOLA 239 PER DF972	1	Fun
10	77	4209392	PREFILTRO GASOLIO KUBOTA	1	Fuel prefilter
10	78	4210599	FLANGIA KUBOTA SERIE 05	1	Flange
10	79	4210600	KUBOTA SERIE 05 SAE A/HV	1	Coupling for Kubota engine
10	80	4210601	MOZZO Z.33-L=30-Z.9-16/32	1	Joint for coupling
10	81	4210604	DISTRIBUTORE MD1 45 BAR	1	Distributor of a lever
10	82	4211034	FASCETTA A COLLARINO D.9-11	1	Clamp D.9-11
10	83	4211045	DISTRIBUTORE 3 LEVE	1	Distributor with three levers
10	84	4300007	VITE TE M10 X 25 UNI 5739 - 8.8 ZINC.	2	Hexagon screw M10x25 ISO 4017/Galvanized







10	85	4300012	DADO BASSO M8 UNI5589	1	Hexagon nut M8 ISO 4035/Galvanized
10	86	4300033	VITE TE M8 X 20 UNI 5739 - 8.8 ZINC.	1	Hexagon screw M8x20 ISO 4017/Galvanized
10	87	4300034	RONDELLA D.10,5 X 21 UNI 6592 ZINC.	36	Flat washer large series D.10,5x 21 ISO 7093 Galvanized
10	88	4300036	RONDELLA D.8,4 X 17 UNI 6592 ZINC.	22	Flat washer large series D.8,4x 17 ISO 7093 Galvanized
10	89	4300048	RONDELLA D.6,4 X 12 UNI 6592 ZINC.	24	Flat washer large series D.6,4x 12 ISO 7093 Galvanized
10	90	4300050	VITE TE M6 X 20 UNI 5739 - 8.8 ZINC.	13	Hexagon screw M6x20 ISO 4017/Galvanized
10	91	4300051	DADO M6 AUTOFRENANTE UNI 7473 ZINC.	11	Hexagon self- locking nut M6 ISO 7040
10	92	4300053	DADO M8 AUTOFRENANTE UNI 7473 ZINC.	27	Hexagon self- locking nut M8 ISO 7040
10	93	4300061	VITE TE M8 X 70 UNI 5739 ZINC.	2	Hexagon screw M8x70 ISO 4017/Galvanized
10	94	4300070	DADO M10 AUTOFRENANTE UNI 7473-6S ZINC.	8	Hexagon self- locking nut M10 ISO 7040
10	95	4300079	DADO MEDIO M6 UNI 5588-6S ZINC.	1	Hexagon nut M6 ISO 4032/Galvanized
10	96	4300107	VITE TE M8X15 UNI5739 ZINC.	2	Hexagon screw M8x15 ISO 4017/Galvanized
10	97	4300108	VITE TE M8 X 30 UNI 5739 ZINC.	4	Hexagon screw M8x30 ISO 4017/Galvanized
10	98	4300114	RONDELLA GROOVER D.8 UNI 1762 ZINC.	4	Split washer D.8 DIN 127/ Galvanized
10	99	4300116	VITE TSPEI M6X16	2	Socket head flat countersunk M6x 16 ISO 10642/Galvanized
10	100	4300126	RONDELLA D.8 X 24 UNI 6593 ZINC.	13	Flat washer large series D.8x24 ISO 7093 Galvanized
10	101	4300148	VITE TBEI M6 X 10 UNI 7380 ZINC.	7	Hexagon socket button cup screw M6x10 ISO 7380/Galvanized
10	102	4300151	VITE TE M8 X 50 1/2 FIL. UNI 5737-8.8 BR	1	Hexagon screw partially treaded M8x50 ISO 4014 Galvanized
10	103	4300173	VITE TBEI M6 X 20 ISO 7380 ZINC.	2	Hexagon socket button cup screw M6x20 ISO 7380/Galvanized
10	104	4300204	VITE TE M10 X 30 UNI 5739 - 8.8 ZINC.	2	Hexagon screw M10x30 ISO 4017/Galvanized
10	105	4300208	VITE TE M6 X 60 UNI 5739 ZINC.	2	Hexagon screw M6x60 ISO 4017/Galvanized
10	106	4300222	VITE TBEI M8X20 UNI7380 ZINC.	4	Hexagon socket button cup screw M8x20 ISO 7380/Galvanized
10	107	4300224	RONDELLA D.6,4 X 18 UNI 6593 ZINC.	20	Flat washer large series D.6,4x18 ISO 7093 Galvanized
10	108	4300232	VITE TBEI M8X30 ZINCATA	2	Hexagon socket button cup screw M8x30 ISO 7380/Galvanized
10	109	4300247	VITE TBEI M6 X 15 UNI 7380 ZINC.	9	Hexagon socket button cup screw M6x15 ISO 7380/Galvanized
10	110	4300256	RONDELLA GROOVER D.10 UNI 1762 ZINC.	12	Split washer D.10 DIN 127/ Galvanized
10	111	4300293	VITE TE M8 X 25 UNI 5739 ZINC.	6	Hexagon screw M8x25 ISO 4017/Galvanized
10	112	4300312	VITE TE M10X25 X1,25	14	Screw TE M10X25 X1,25
10	113	4300318	VITE TCEI M8X30 UNI5931 8G ZINC.	3	Socket head cup screw M8x30 ISO4762 Galvanized
10	114	4300319	VITE TCEI M8X25 UNI5931 ZINC.	6	Socket head cup screw M8x25 ISO4762 Galvanized
10	115	4300328	VITE TCEI M10 X 35 UNI 5931 - 8.8 ZINC.	2	Socket head cup screw M10x35 ISO4762 Galvanized
10	116	4300347	VITE TCEI M10 X 30 PASS.1,25 ZINC	3	Screw TE M10X30 PASS.1,25 ZINC
10	117	4300201	VITE AUTOFILETTANTE 3,9 X 15	6	Self-tapping screw 3,9x 15 ISO 7049/Galvanized
10	118	4300366	VITE TSPEI M8 X 45 UNI 5933 1/2 FIL.	2	Screw TSPEI M8 X 45 UNI 5933 1/2 FIL.
10	119	4300437	VITE TSPEI M6 X 20 UNI 5933 - 8.8 ZINC	2	Socket head flat countersunk M6x 20 ISO 10642/Galvanized
10	120	4300479	VITE T.S.P.E.I. M8X35 UNI5933 ZINC.	2	Socket head flat countersunk M8x 35 ISO 10642/Galvanized
10	121	4210538	MOTORE DIESEL KUBOTA D1105	1	Kubota Engine D1105
10	122	4210094	CINGHIA PER KUBOTA D1105	1	Belt KUBOTA D1105
10	123	4201627	FILTRO OLIO	1	Engine diesel oil filter
10	124	4300056	DADO M4 AUTOBLOCCANTE	6	Hexagon self- locking nut M4 ISO 7040
10	125	3012203	LISTELLO FISSAGGIO SERBATOIO (da mat.6469)	2	Fixing fuel tank (from s/n 6469)
10	126	3011613	SERBATOIO GASOLIO (da mat.6469)	1	Fuel tank (from s/n 6469)
10	127	3012202	SUPPORTO SERBATOIO GASOLIO (da mat.6469)	1	Support Fuel tank (from s/n 6469)
10	128	4201558	Pompa PZ 14cc sercocomando idraulico (da mat.6519)	1	Pump PZ 14cc (from s/n 6519)
		Part Nr	refers always to one single parts		



TAB.	POS.	Part Nr	DENOMINAZIONE	Q.ty	Description
11	1	3009611	PANNELLINO CHIAVE AVVIAMENTO	1	Ignition key panel
11	2	3010074	ETICHETTA PANNELLINO CHIAVE AVVIAMENTO	1	Label ignition key panel
11	3	3010865	PANNELLO LEVA SPAZZOLA LATERALE	1	Plate side broom
11	4	3010882	ETICHETTA PANNELLO SPAZZOLA LATERALE	1	Label plate side broom
11	5	3010908	CRUSCOTTO 160	1	Dashboard
11	6	3010909	CRUSCOTTO INFERIORE	1	Bulkhead
11	7	3011253	ANGOLARE ANTERIORE CORTO	1	Dashboard holder
11	8	3011254	ANGOLARE ANTERIORE LUNGO	1	Dashboard holder
11	9	3011255	PIASTRA LEVE	1	Plate levers
11	10	3011256	PIATTO SUPPORTO RELÉ	1	Support plate relay
11	11	4200096	QUADRO AVVIAMENTO	1	Ignition switch
11	12	4200118	TRECCIA 0.52A MM.350	1	Copper cable 0.52A mm 350
11	13	4200227	CLACSON 12V	1	Klaxon 12 V
11	14	4200230	RELÉ BOSCH 12V 30/40A 0332 / 209150	3	Relay 12V 30/40 A
11	15	4200234	FUSIBILE 25 A	1	Fuse 25A
11	16	4200238	FUSIBILE 15 A	1	Fuse 15A
11	17	4200250	FUSIBILE 10 A	3	Fuse 10A
11	18	4200581	TAPPO	2	Cup
11	19	4200780	FUSIBILE 30 A	1	Fuse 30A
11	20	4200930	FUSIBILE 7,5 A	1	Fuse 7,5A
11	21	4201029	RELÉ 12V 70 AH	2	Relay 12V 70 A
11	22	4201708	CONTAORE IMEL DIS. N°S17903 I-A	1	Hour meter IMEL dis. N°S17903 I-A
11	23	4201745	SCATOLA FUSIBILI 6 VIE MERIT IMEL COD. F17135	2	Fuse box 6 way merit IMEL cod. F17135
11	24	4201768	INDICATORE LIVELLO GASOLIO	1	Fuel level indicator
11	25	4201846	FUSIBILE 3 A	2	Fuse 3A
11	26	4201946	FUSIBILE 5 A MARRONE TERRA DI SIENA	3	Fuse 5A tan
11	27	4209987	TIMER CANDELETTE KUBOTA	1	Preheating timer
11	28	4210282	MOSTRINA CENTRALE	3	Switch box
11	29	4210283	MOSTRINA ESTERNA	2	Switch box
11	30	4210284	INTERRUTTORE 0-1 INSTABILE	1	Switch (horn)
11	31	4210285	INTERRUTTORE 1-0-2	1	Switch (fan & filter shaker)
11	32	4210287	PULSANTE CLACSON	1	Switch cover (horn)
11	33	4210288	PULSANTE VENTOLA E SCUOTIFILTRO	1	Switch cover (fan & filter shaker)
11	34	4210352	TAPPO	3	Cup for switch
11	35	4300048	RONDELLA D.6,4 X 12 UNI 6592 ZINC.	4	Flat washer 6,4x12 ISO 7089 Galvanized
11	36	4300049	RONDELLA D.4,3 X 9 UNI 6592 ZINC.	3	Flat washer 4,3x9 ISO 7089 Galvanized
11	37	4300051	DADO M6 AUTOFRENANTE UNI 7473 ZINC.	2	Hexagon self-locking nut M6 ISO 7040
11	38	4300056	DADO M4 AUTOFRENANTE UNI 7473 ZINC.	6	Hexagon self-locking nut M4 ISO 7040
11	39	4300079	DADO MEDIO M6 UNI 5588-6S ZINC.	2	Hexagon nut M6 ISO 4032/Galvanized
11	40	4300155	DADO IN GABBIA M6	4	Cage nut M6
11	41	4300158	VITE TBEI M4 X 12 UNI7380	6	Hexagon socket button cup screw M4x12 ISO 7380/Galvanized
11	42	4300201	VITE AUTOFILETTANTE 3,9 X 15	8	Self-tapping screw 3,9x 15/9 nickel
11	43	4300225	VITE TBEI M4 X 8 UNI 7380	1	Hexagon socket button cup screw M4x8 ISO 7380/Galvanized
11	44	4300243	VITE TBEI UNI ISO 7380 M6 X 30	2	Hexagon socket button cup screw M6x30 ISO 7380/Galvanized
11	45	4300247	VITE TBEI M6 X 15 UNI 7380 ZINC.	12	Hexagon socket button cup screw M6x15 ISO 7380/Galvanized
11	46	4300407	RIVETTO A STRAPPO ESAGONALE M6	8	Hexagonal rivet M6
11	47	3011425	ETICHETTA PIASTRA LEVE	1	Label plate levers
11	48	2110842	KIT IMPIANTO ELETTRICO	1	Electric wiring kit
11	49	3003241	CAVO BATTERIA AVVIAMENTO +	1	Battery cable +
11	50	3003242	CAVO BATTERIA AVVIAMENTO -	1	Battery cable -
11	51	4200657	SIRENA PIE 20	1	Hooter PIE 20
11	52	4201225	CHIAVE	1	Key

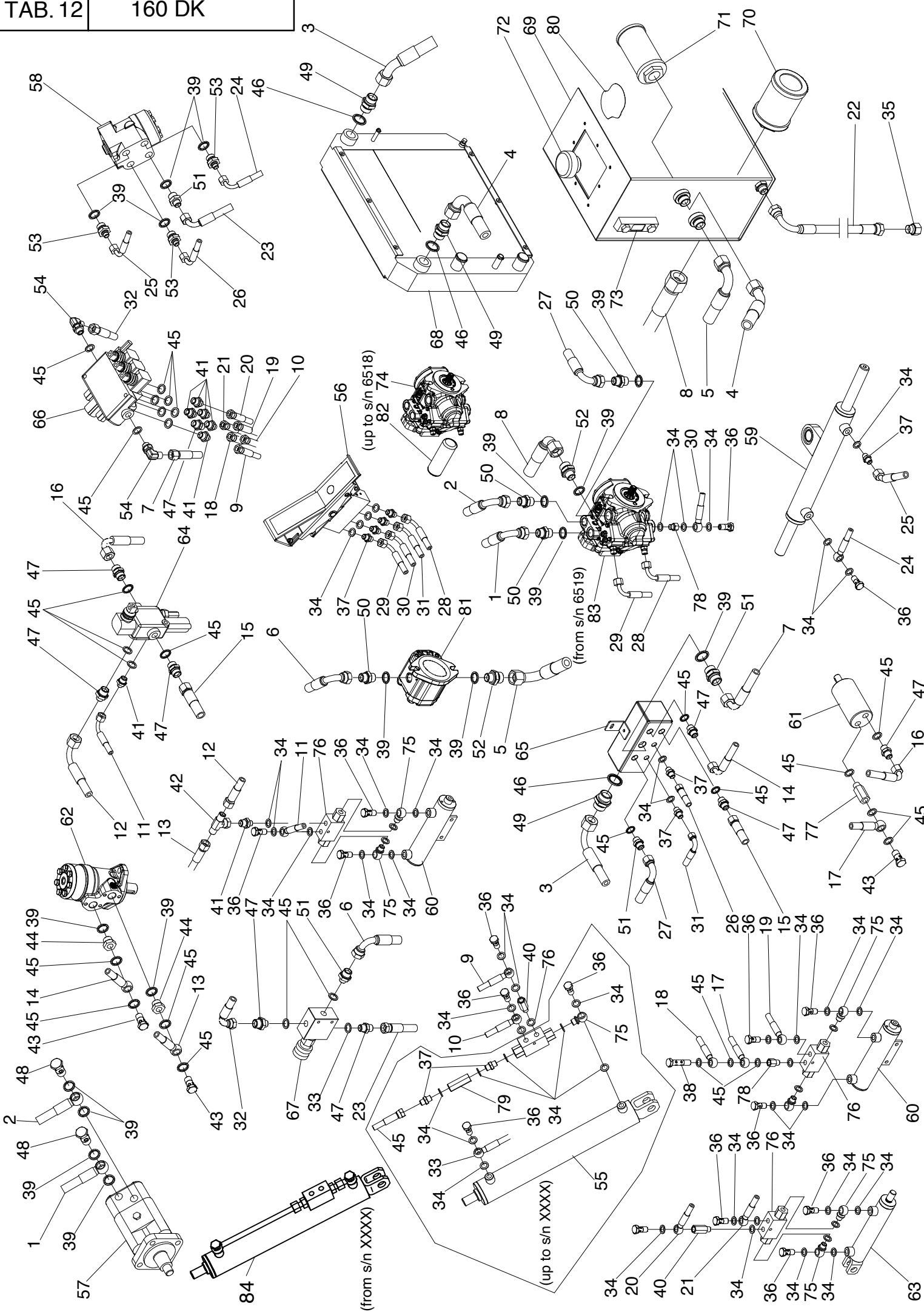

TAB.	POS.	PART Nr	DENOMINAZIONE	Q.ty	Description
12	1	3011293	Tubo da pompa PV a motore ruota	1	Hydraulic pipe from Variable Pump to wheel hydraulic motor
12	2	3011294	Tubo da pompa PV a motore ruota	1	Hydraulic pipe from Variable Pump to wheel hydraulic motor
12	3	3011295	Tubo da raccogliore a scambiatore	1	Hydraulic pipe from collector to heat exchanger
12	4	3011296	Tubo da scambiatore a serbatoio olio	1	Hydraulic pipe from heat exchanger to oil tank
12	5	3011297	Tubo da serbatoio olio a pompa ingranaggi	1	Hydraulic pipe from oil tank to gear pump
12	6	3011298	Tubo da valvola prioritaria a pompa ingranaggi	1	Hydraulic pipe from priority valve to gear pump
12	7	3011299	Tubo da distributore 3 leve a raccogliore olio	1	Hydraulic pipe from 3 element distributor to oil collector
12	8	3011300	Tubo da serbatoio olio a pompa PV	1	Hydraulic pipe from oil tank to variable pump
12	9	3011301	Tubo da distributore 3 leve a cilindro contenitore	1	Hydraulic pipe from 3 element distributor to lifting cylinder for container
12	10	3011302	Tubo da distributore una leva a cilindro contenitore	1	Hydraulic pipe from 3 element distributor to lifting cylinder for container
12	11	3011303	Tubo da distributore una leva a cilindro spazz.laterale	1	Hydraulic pipe from single distributor to side broom cylinder
12	12	3011304	Tubo da distributore una leva a cilindro spazz.laterale	1	Hydraulic pipe from single distributor to side broom cylinder
12	13	3011305	Tubo da cilindro spazz.laterale a motore spazz.laterale	1	Hydraulic pipe from side broom cylinder to side motor cylinder
12	14	3011306	Tubo da motore spazz.laterale a raccogliore olio	1	Hydraulic pipe from side motor cylinder to oil collector
12	15	3011307	Tubo da distributore una leva a raccogliore olio	1	Hydraulic pipe from single distributor to oil collector
12	16	3011676	Tubo da distributore una leva a motore spazz.centrale	1	Hydraulic pipe from single distributor to main broom hydraulic motor
12	17	3011675	Tubo da cilindro spazz.centrale a motore spazz.centrale	1	Hydraulic pipe from main broom cylinder to main broom hydraulic motor
12	18	3011674	Tubo da distributore 3 leve a cilindro spazz.centrale	1	Hydraulic pipe from 3 element distributor to main broom cylinder
12	19	3011311	Tubo da distributore 3 leve a cilindro spazz.centrale	1	Hydraulic pipe from 3 element distributor to main broom cylinder
12	20	3011312	Tubo da distributore 3 leve a cilindro flap	1	Hydraulic pipe from 3 element distributor to flap cylinder
12	21	3011313	Tubo da distributore 3 leve a cilindro flap	1	Hydraulic pipe from 3 element distributor to flap cylinder
12	22	3007860	Tubo scarico serbatoio olio	1	Oil tank drain hose
12	23	3011314	Tubo da valvola prioritaria a idroguida	1	Hydraulic pipe from priority valve to power steering
12	24	3011315	Tubo da idroguida a cilindro sterzo	1	Hydraulic pipe from hydroguide to power steering cylinder
12	25	3011316	Tubo da idroguida a cilindro sterzo	1	Hydraulic pipe from hydroguide to power steering cylinder
12	26	3011317	Tubo da idroguida a raccogliore olio	1	Hydraulic pipe from hydroguide to oil collector
12	27	3011318	Tubo da pompa PV a raccogliore olio	1	Hydraulic pipe from Variable Pump to oil collector
12	28	3011319	Tubo da pedipolatore a pompa PV	1	Hydraulic pipe from pedal to Variable Pump
12	29	3011320	Tubo da pedipolatore a pompa PV	1	Hydraulic pipe from pedal to Variable Pump
12	30	3011321	Tubo da pedipolatore a pompa PV	1	Hydraulic pipe from pedal to Variable Pump
12	31	3011322	Tubo da pedipolatore a raccogliore olio	1	Hydraulic pipe from pedal to oil collector
12	32	3011323	Tubo da valvola prioritaria a distributore 3 leve	1	Hydraulic pipe from priority valve to 3 element distributor
12	33	3011324	Tubo da valvola unidirezionale a cilindro sollevamento (Fino a matr. xxxxx)	1	Hydraulic pipe from one-way valve to lifting cylinder (Up to s/n xxxxx)
12	34	4200491	Rondella bonded seal 1/4"	53	Bonded seal washer 1/4"
12	35	4201716	Tappo 1/2"M (BSP 60°)	1	Cap 1/2"M ( BSP 60°)
12	36	4200699	Bullone forato per occhio 1/4"	16	Pipe union 1/4"
12	37	4200712	Nipplo 1/4" (BSP 60°)	9	Nipple 1/4" (BSP 60°)
12	38	4200702	Bullone forato doppio 3/8"	1	Pipe union 3/8"
12	39	4200490	Rondella bonded seal 1/2"	17	Bonded seal washer 1/2"
12	40	4200708	Prolunga M-M 1/4"	2	Male-Male extension 1/4"
12	41	4200715	Nipples di riduzione 1/4" - 3/8"	7	Nipple 1/4"-3/8"
12	42	4200706	Adattatore "T" 3/8" M-F-M girello a centro	1	"T" adaptor 3/8" M-F-M
12	43	4200700	Bullone forato per occhio 3/8"	3	Pipe union 3/8"
12	44	4200704	Riduzione bassa 1/2"M- 3/8"F	2	Reduction bush 1/2"M -3/8"F
12	45	4200473	Rondella bonded seal 3/8"	29	Bonded seal washer 3/8"
12	46	4200474	Rondella bonded seal 3/4"	3	Bonded seal washer 3/4"
12	47	4200713	Nipplo G3/8" (BSP 60°)	10	Nipple G3/8" (BSP 60°)
12	48	4200701	Bullone forato per occhio 1/2"	2	Pipe union 1/2"
12	49	4200899	Nipplo 3/4" (BSP 60°)	3	Nipple 3/4" (BSP 60°)
12	50	4200714	Nipplo G1/2" (BSP 60°)	5	Nipple G1/2" (BSP 60°)
12	51	4200716	Nipplo 3/8" - 1/2" (BSP 60°)	2	Nipple 3/8" - 1/2" (BSP 60°)
12	52	4200764	Nipplo 1/2" - 3/4"	2	Nipple 1/2" - 3/4"
12	53	4200942	Nipplo 1/2" - 1/4"	3	Nipple 1/2" - 1/4"
12	54	4210032	Gomito M-M orientabile 3/8"-3/8"	2	Elbow M-M orientable 3/8"-3/8"
12	55	3008258	Cilindro sollevamento contenitore (Fino a matr. xxxxx)	1	Lifting cylinder for container (Up to s/n xxxxx)
12	56	4210864	Pedipolatore	1	Control pedal
12	57	4200631	Motore idraulico OMS 250 SAUER-DANFOSS	1	Hydraulic motor OMS 250
12	58	4200830	Idroguida OSPC 50	1	Power steering OSPC 50
12	59	3002708	Cilindro idroguida	1	Power steering cylinder
12	60	3002233	Cilindro spazzole	2	Broom cylinder
12	61	4201064	Motore idraulico 40cc	1	Hydraulic motor 40cc
12	62	4201065	Motore idraulico OMP 200	1	Hydraulic motor OMP 200
12	63	3002231	Cilindro flap	1	Flap cylinder
12	64	4210604	Distributore una leva MD1 45 Bar	1	Distributor of a lever MD1 45 Bar
12	65	2106944	Raccogliore olio	1	Oil collector
12	66	4211045	Distributore 3 leve	1	Distributor level three
12	67	4200813	Valvola prioritaria 3/8"	1	Priority valve
12	68	3010756	Radiatore combinato ACQUA / OLIO	1	Combined radiator water/oil
12	69	2110812	Serbatoio olio "C"	1	Oil tank
12	70	4201277	Filtro 10 M	1	Filter element
12	71	4200614	Filtro olio 1" 25 M	1	Suction oil filter 1" 25 micron
12	72	4200508	Tappo serbatoio olio con sfianto 1" 1/4	1	Air hole cup 1" 1/4"
12	73	4200615	Indicatore ottico di livello	1	Level indicator
12	74	4201777	Pompa PV P0 14 CC (fino a matr. 6518)	1	Hydraulic variable pump P014 CC (Up to s/n 6518)
12	75	4200711	Occhio filettato con battuta 1/4"	7	Treaded grommet 1/4"
12	76	4200636	Vaivola di blocco 1/4" 0,5 BAR	4	Stop valve 1/4" 0,5 BAR
12	77	4200709	Prolunga M-F 3/8" L.40	1	Extension M-F 3/8" L.40
12	78	4200707	Riduzione 1/4" M-3/8" F	1	Reduction bush 1/4" M -3/8" F
12	79	4201752	Valvola unidirezionale BSPP1/4" (Fino a matr. xxxxx)	1	One way valve BSPP1/4" (Up to s/n xxxxxx)
12	80	4000649	Olio idraulico ISO VG 46 in litri	31	Hydraulic oil ISO VG 46 ISO 3448 (DIN 51519) lt
12	81	4200945	Pompa ingranaggi 8,5 CC	1	Gear pump 8,5 cc
12	82	4201778	Filtro per pompa PV	1	Filter hydraulic variable pump
12	83	4201558	POMPA PZ 14 CC (Da matr. 6519)	1	Hydraulic pump Pz14 CC (From s/n 6519)
12	84	3002232	Cilindro flap (Da matr. xxxxx)	1	Flap cylinder (From s/n xxxxx)
		Part Nr	refers always to one single parts		

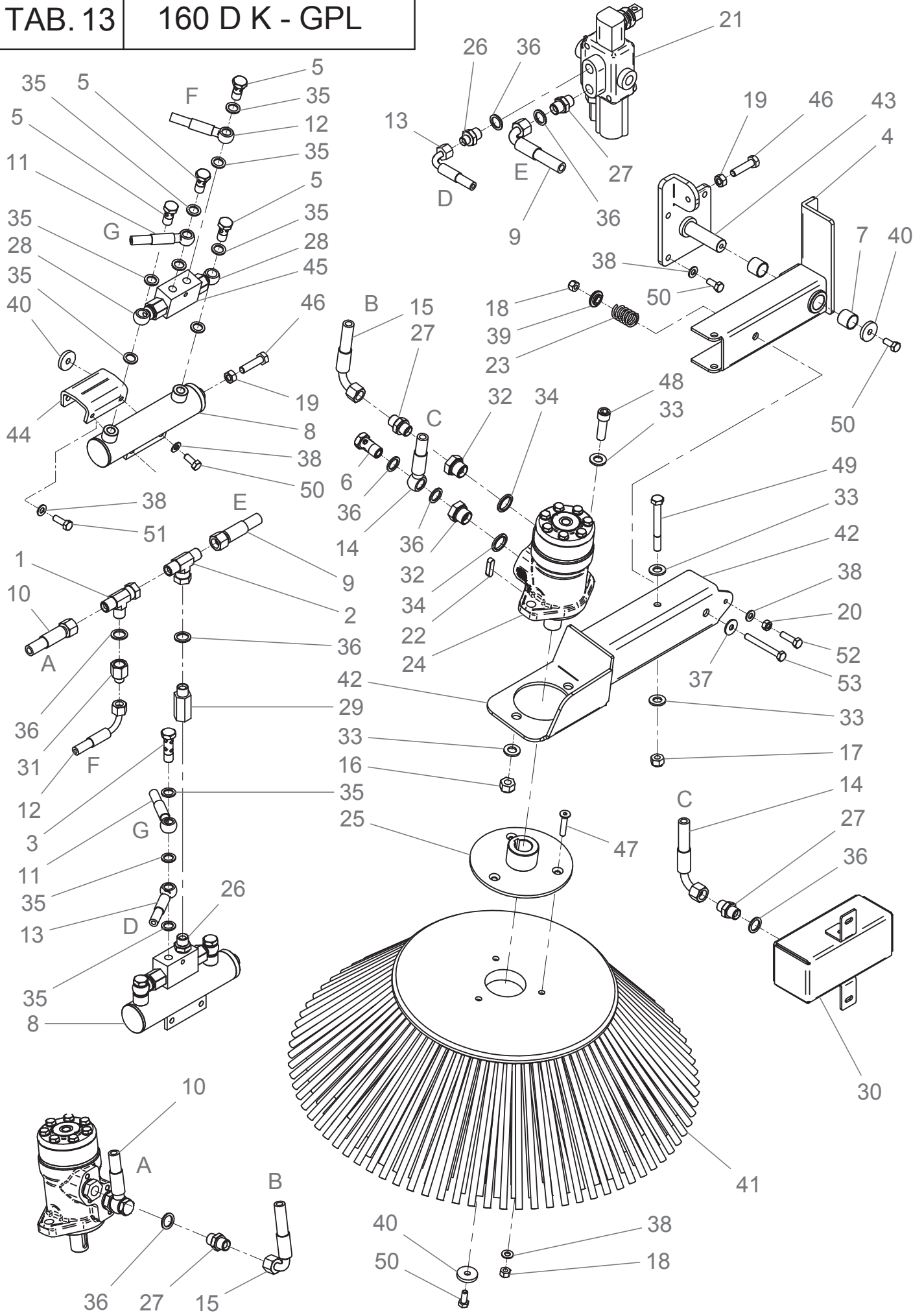

TAB.	Pos.	Part Nr	DENOMINAZIONE	Q.ty	Description
13	1	4200745	Adattatore a" T" M - M - F GIR. 3/8	1	"T" adaptor 3/8" M-M-F
13	2	4200706	Adattatore "T" 3/8" M-F-M girello a centro	1	"T" adaptor 3/8" M-F-M
13	3	4200767	Bocchettone doppio da 1/4"	1	Pipe union double 1/4"
13	4	2101512	Braccio spazzola laterale sinistro	1	Left side broom arm
13	5	4200699	Bullone forato per occhio 1/4"	6	Pipe union 1/4"
13	6	4200700	Bullone forato per occhio 3/8"	2	Pipe union 3/8"
13	7	4200622	Bussola K4 20 X 23 X 20	2	Socket K4 20x23x20
13	8	3002233	Cilindro spazzole	2	Main broom cylinder
13	9	3011304	Tubo idraulico da distributore 1 leva a cil.spazz.centrale	1	Hydraulic pipe from single distributor to main broom cylinder
13	10	3011305	Tubo idraulico da cil. spazz. lat. a motore spazz. laterale	1	Hydraulic pipe from main broom cylinder to main broom hydraulic motor
13	11	3001568	Tubo idraulico da cilindro a cilindro	1	Hydraulic pipe from side broom cylinder to side broom cylinder
13	12	3001569	Tubo idraulico da cilindro a cilindro	1	Hydraulic pipe from side broom cylinder to side broom cylinder
13	13	3011303	Tubo idraulico da distributore 1 leva a cil.spazz.laterale	1	Hydraulic pipe from single distributor to side broom cylinder
13	14	3011306	Tubo idraulico da motore spazz. lat. a raccogliore olio	1	Hydraulic pipe from side motor cylinder to oil collector
13	15	3001566	Tubo idraulico da spazzola Dx a spazzola SX	1	Hydraulic pipe from side motor cylinder to side motor cylinder
13	16	4300112	DADO M12 AUTOFRENANTE UNI 7473 / ZINC.	2	Hexagon self-locking nut M12 ISO 7040
13	17	4300070	Dado M10 autofrenante UNI 7473-6S zinc.	1	Hexagon self-locking nut M10 ISO 7040
13	18	4300053	Dado M8 autofrenante UNI 7473 zinc.	4	Hexagon self-locking nut M8 ISO 7040
13	19	4300178	Dado medio M10 UNI 5588 zinc.	2	Exagon nut M10 ISO 4032 / Galvanized
13	20	4300029	Dado medio M8 UNI 5588-6S zinc.	1	Exagon nut M8 ISO 4032 / Galvanized
13	21	4210604	Distributore MD1 45 Bar	1	Distributor MD1 45 Bar
13	22	4200922	Linguetta 8X7X32 UNI 6604	1	key 8x7x32 ISO 773A
13	23	4200693	Molla rientro spazzola	1	Spring
13	24	4201065	Motore idraulico OMP 200	2	Hydraulic motor OMP 200
13	25	2101938	Mozzo spazzola laterale	1	Side broom hub
13	26	4200715	Nipples di riduzione 1/4" - 3/8"	2	Nipple 1/4" - 3/8"
13	27	4200713	Nipplo G3/8" (BSP 60°)	4	Nipple G 3/8" (BSP 60°)
13	28	4200711	Occhio filettato con battuta 1/4"	4	Treaded grommet 1/4"
13	29	4200709	Prolunga M-F 3/8" L=40	1	Male-female extension 3/8" L.40 mm
13	30	2106944	Raccogliore olio "C"	1	Oil collector
13	31	4200707	Riduzione 1/4"M - 3/8"F (BSP 60°)	1	Reduction 1/4"M - 3/8"F (BSP 60°)
13	32	4200704	Riduzione bassa 1/2"M- 3/8"F	4	Reduction bush 1/2"M - 3/8"F
13	33	4300058	Rondella 13 X 24 UNI6592 zinc.	6	Flat washer D.13 x 24 ISO 7089 / Galvanized
13	34	4200490	Rondella bonded seal autocentrante 1/2"	4	Bonded seal washer 1/2"
13	35	4200491	Rondella bonded seal autocentrante 1/4"	20	Bonded seal washer 1/4"
13	36	4200473	Rondella bonded seal autocentrante 3/8"	11	Bonded seal washer 3/8"
13	37	4300126	Rondella D.8 x 24 UNI 6593 zinc.	1	Flat washer large series D.8 x 24 ISO 7093 / Galvanized
13	38	4300036	Rondella D.8,4 X 17 UNI 6592 zinc.	12	Flat washer D. 8,4x17 ISO 7089 / Galvanized
13	39	3001511	Rondella di fermo molla	1	Spring stop washer
13	40	3000098	Rondella per albero di comando	4	Washer for drive shaft
13	41	3007959	SPAZZOLA LATERALE	1	Side broom PP
13	42	2103489	Supporto motore spazzola SX	1	Left broom arm
13	43	2101629	Supporto spazzola sinistro	1	Left broom support
13	44	3001583	Supporto SX per martin. spazz.	1	Left cylinder support
13	45	4200636	Valvola di blocco 1/4" 0,5 BAR	2	Stop valve 1/4" 0,5 BAR
13	46	4300227	VITE T.E. M10X40 UNI5739 zinc.	2	Hexagon screw M10x40 ISO 4017 / Galvanized
13	47	4300289	VITE T.S.P.E.I. M8X40	3	Socket head flat countersunk M8x40 ISO 10642 Galvanized
13	48	4300209	VITE TCEI M12 X 40 UNI 5931 zinc.	2	Socket head cup screw M12x40 ISO4762 Galvanized
13	49	4300006	Vite TE M10 x 85 1/2 fil. UNI 5737 zinc.	1	Hexagon screw M10x85 ISO 4017 / Galvanized
13	50	4300033	Vite TE M8 X 20 UNI 5739 - 8.8 zinc.	8	Hexagon screw M8x20 ISO 4017 / Galvanized
13	51	4300293	Vite TE M8 X 25 UNI 5739 zinc.	2	Hexagon screw M8x25 ISO 4017 / Galvanized
13	52	4300108	Vite TE M8 X 30 UNI 5739 zinc.	1	Hexagon screw M8x30 ISO 4017 / Galvanized
13	53	4300061	Vite TE M8 x 70 UNI 5739 zinc.	1	Hexagon screw M8x70 ISO 4017 / Galvanized
		Part Nr	refers always to one single parts		

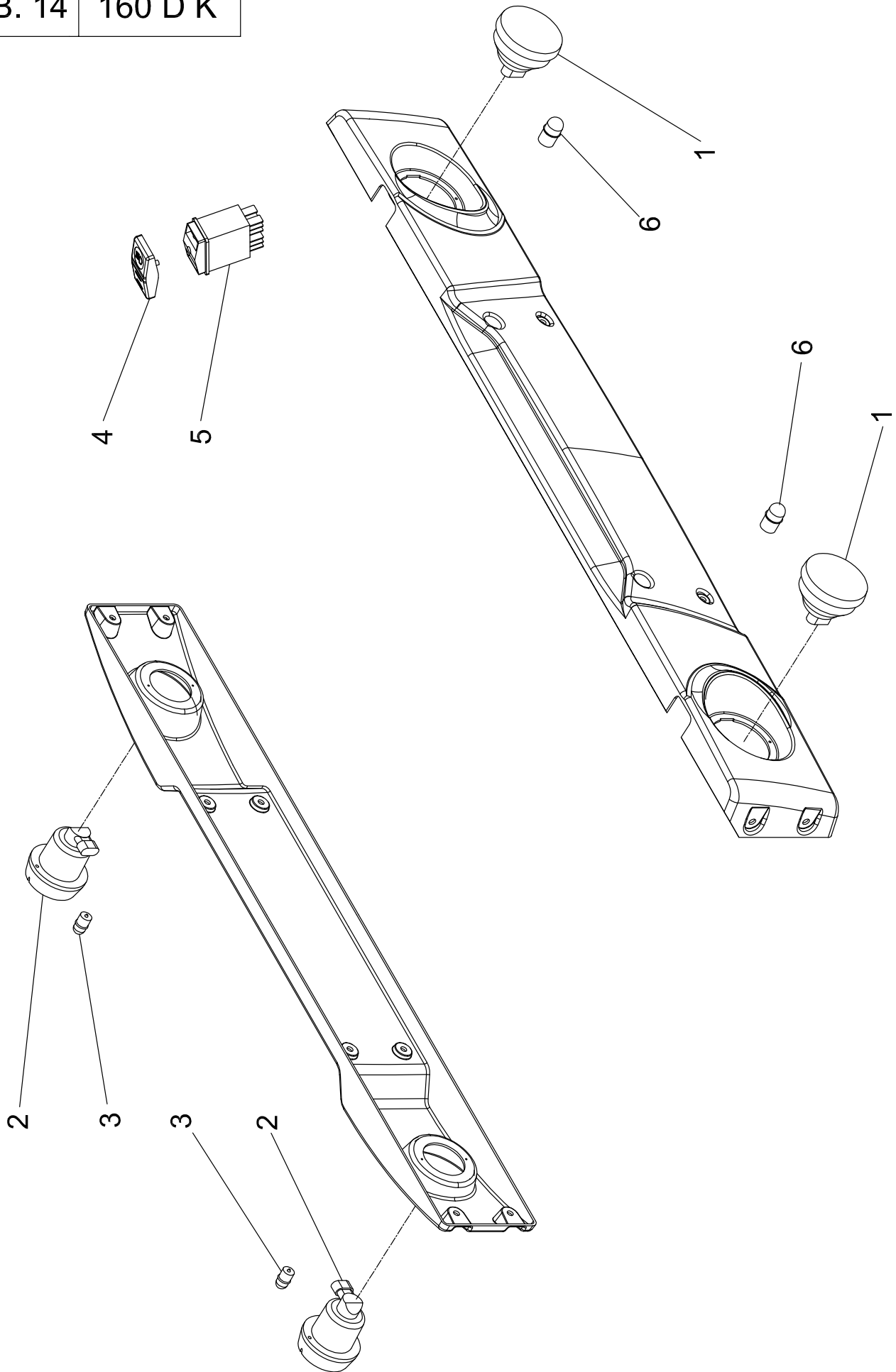



TAB.	POS.	Part Nr	DENOMINAZIONE	Q.ty	Description
14	1	4201310	FANALE DI LAVORO	2	Working light
14	2	4210807	FANALE POSTERIORE	2	Rear light
14	3	4201806	LAMPADA 12V-5W ATTACCO BA15S	2	Lamp 12V-5W BAY BA15S
14	4	4210289	PULSANTE LUCE	1	Switch cover (Ligth)
14	5	4210286	INTERRUTTORE 0-1 STABILE	1	Switch (Ligth)
14	6	4209794	LAMPADA PER FARO DI LAVORO GE886	2	Lamp GE886
		Part Nr	refers always to one single parts		



TAB.	POS.	Part Nr	DENOMINAZIONE	Q.ty	Description
15	1	4201857	BRACCIO TERGIVETRO	2	Wiper arm
15	2	2108758	ATTACCO LEVA "C"	1	Coupling lever
15	3	4200212	CHIUSURA A LEVA	1	Closing with lever
15	4	4300012	DADO BASSO M8 UNI 5589 ZINC.	2	Exagon nut M8 ISO 4035/Galvanized
15	5	518537009	DADO ESAG. A FRENATURA CENTRALE M8 X 6.5 DIN980	1	Exagon nut M8 DIN 980/Galvanized
15	6	4300070	DADO AUTOFRENANTE M10 UNI 7476 ZINC.	4	Hexagon self- locking nut M10 ISO 7040
15	7	4300053	DADO AUTOFRENANTE M8 UNI7473 ZINC.	4	Hexagon self- locking nut M8 ISO 7040
15	8	4300117	DADO MEDIO M4 UNI 5588 ZINC.	2	Exagon nut M4 ISO 4032/Galvanized
15	9	3003697	FERMO PER CABINA	2	Cab stop
15	10	2108785	FERMO PER CABINA "C"	1	Cab stop "C"
15	11	4200875	GIROFARO 12V MAGNETICO	1	Rotating flash 12V magnetic base
15	12	4210285	INTERRUTTORE 1-0-2	1	Switch
15	13	4200724	LAMPADA 12V-5W	1	Lamp 12V-5W
15	14	2108784	LEVA SICUREZZA CABINA "C"	1	Lever safety cab
15	15	4200014	MANIGLIA PER COFANO	1	Handle
15	16	4201204	MOLLA A GAS D.STELO	1	Gas spring
15	17	4201856	MOTORE TERGIVETRO	1	Screen wiper
15	18	4201252	PRESA FEMMINA PER GIROFARO	1	Female socket for rotating flash
15	19	4300034	RONDELLA D.10,5X 21 UNI 6592 / ZINC.	4	Flat washer 10,5x21 ISO 7089 Galvanized
15	20	4300049	RONDELLA D. 4,3 X 9 UNI 6592 ZINC.	8	Flat washer 4,3 x 9 ISO 7089 Galvanized
15	21	4300224	RONDELLA D. 6,4 X 18 UNI 6593 ZINC.	6	Flat washer large series D.6,4 x18 ISO 7093 Galvanized
15	22	4300126	RONDELLA D. 8 X 24 UNI 6592 ZINC.	7	Flat washer large series 8 x 24 ISO 7093 Galvanized
15	23	4200859	SERBATOIO ACQUA + POMPA	1	Screen wash water reservoir
15	24	4201858	SPAZZOLA TERGIVETRO	1	Wiper
15	25	3008051	SUPPORTO ATTACCO GIROFARO	1	Rotating flash female socket support
15	26	3011257	SUPPORTO VASCHETTA TERGI	1	Support for water reservoir
15	27	3008740	TELO DI PROTEZIONE DESTRO	1	Right plastic curtains
15	28	3008738	TELO DI PROTEZIONE POSTERIORE	1	Rear plastic curtains
15	29	3008739	TELO DI PROTEZIONE SINISTRO	1	Left plastic curtains
15	30	2103810	TETTuccio	1	Open cab
15	31	4200861	TUBO ALIMENTAZIONE ACQUA	1	Water hose
15	32	4200857	UGELLO ACQUA	1	Water nozzle
15	33	4200860	VALVOLA DI NON RITORNO	1	One direction valve
15	34	3003873	VETRO TETTuccio	1	Cab glass
15	35	4300210	VITE TSPEI M8 X 20 UNI 5933 - 8.8 ZINC.	3	Socket head flat countersunk M8x20 ISO 10642/Galvanized
15	36	4300172	VITE TBEI M6X20 ISO 7380 ZINC.	2	Hexagon socket button cup screw M6x20 ISO 7380/Galvanized
15	37	4300158	VITE TBEI M4 X 12 UNI 7380	4	Hexagon socket button cup screw M4x12 ISO 7380/Galvanized
15	38	4300439	VITE TBTC M4 X 25 ZINC.	2	Screw M 4 x 25 ISO 7048 Galvanized
15	39	4300052	VITE TCEI M8 X 20 UNI 5931 - 8.8 ZINC.	2	Socket head cup screw M8x20 ISO4762 Galvanized
15	40	4300352	VITE TE M6 X 12 UNI 5739 /ZINC	2	Hexagon screw M6x12 ISO 4017/Galvanized
15	41	4300050	VITE TE M6 X 20 UNI 5739 /ZINC	2	Hexagon screw M6x20 ISO 4017/Galvanized
15	42	4300245	VITE TSPEI M10X35 UNI 5933 /ZINC.	4	Socket head flat countersunk M10x35 ISO10642 Galvanized
15	43	4300254	VITE TSPEI M6 X 12 UNI 5933 ZINC.	2	Socket head flat countersunk M6x12 ISO 10642/Galvanized
15	44	4300059	VITE TSPTC M4 X 10 UNI 7688 / ZINC.	45	Socket head flat countersunk M4x10 ISO 7046 Galvanized
15	45	4211884	PULSANTE TERGI	1	Switch cover
		Part Nr	refers always to one single parts		

## IT

La ISAL s.r.l. si riserva di apportare modifiche alle proprie macchine in qualsiasi momento e senza preavviso.

Non si risponde per danni e/o lesioni derivanti da un utilizzo diverso da quello qui specificato o dall'inosservanza delle istruzioni contenute nel presente manuale.

STAMPATO IN ITALIA - Edizione 09/2015

## EN

ISAL s.r.l. reserves the right to modify its machines at any time without prior notice or obligation.

ISAL s.r.l. declines any and all liability for injury and/or damage caused by use of the machine other than that specified or failure to observe the instructions detailed in this manual.

PRINTED IN ITALY - Edition 09/2015

## FR

ISAL s.r.l. se réserve le droit d'apporter les modifications à ses machines à tout moment et sans préavis.

ISAL s.r.l. décline toute responsabilité en cas de dommages dus à une mauvaise utilisation ou à l'inobservation des instructions de ce manuel.

IMPRIME EN ITALIE - Edition 09/2015

## DE

Firma ISAL s.r.l. behält sich das Recht vor, jederzeit ohne Vorbescheid Änderungen an ihren Maschinen vorzunehmen.

Der Hersteller haftet nicht für Schäden und/oder Verletzungen infolge der Benutzung, die nicht der hier beschriebenen entspricht, oder infolge der Nichtbeachtung der Anweisungen, die in diesem Handbuch stehen.

IN ITALIEN GEDRUCKT - Ausgabe 09/2015

## ES

ISAL s.r.l. se reserva el derecho de realizar modificaciones en sus maquinas en cualquier momento sin previo aviso.

No se hace responsable de los daños y/o lesiones provocados por un uso diferente al que se especifica aquí o por no respetar las instrucciones de este manual.

IMPRESO EN ITALIA - Edición 09/2015



**ISAL s.r.l. con Unico Socio**

Società soggetta all'attività di direzione e coordinamento di Kaercher Beteiligungs GmbH

**ISAL S.r.l. Via P.Colletta, 19  
42124 REGGIO EMILIA- ITALY**

**Tel. + 39.0522.823011**

**Fax. + 39.0522.823030**

**E-mail: [isal@isalsweepers.com](mailto:isal@isalsweepers.com)**

**[www.isalsweepers.com](http://www.isalsweepers.com)**